



Cisco Catalyst 9200 Series Switches Hardware Installation Guide

First Published: 2018-11-19

Last Modified: 2022-07-19

Americas Headquarters

Cisco Systems, Inc.
170 West Tasman Drive
San Jose, CA 95134-1706
USA
<http://www.cisco.com>
Tel: 408 526-4000
800 553-NETS (6387)
Fax: 408 527-0883



CONTENTS

CHAPTER 1

Product Overview 1

- Switch Models 1
- Front Panel Components 3
 - 10/100/1000 Ports 4
 - PoE and PoE+ Ports 4
 - Multigigabit Ethernet Ports 5
 - Management Ports 5
 - USB Type A Port 6
 - SD Card Slot 6
 - Uplink Ports 7
- Rear Panel 9
 - RFID Tag 10
 - StackWise Ports 10
 - Auxiliary Power Adapter 10
 - Power Supply Modules 11
 - Fan Modules 13
 - Ethernet Management Port 14
 - RJ-45 Console Port 14
- Network Configurations 14

CHAPTER 2

Preparing for Installation 15

- Safety Warnings 15
- Installation Guidelines 17
- Site Requirements 18
 - Temperature 19
 - Air Flow 19

Humidity	20
Altitude	20
Dust and Particles	20
Air Quality	21
Corrosion	21
EMI and Radio Frequency Interference	22
Shock and Vibration	23
Power Source Interruptions	23
System Grounding	24
Maintaining Safety with Electricity	26
Preventing ESD Damage	27
Tools and Equipment	27
Verifying Switch Operation	28

CHAPTER 3**Installing the Switch 29**

Shipping Box Contents	29
Planning a Switch Data Stack	30
Switch Stacking Guidelines	30
Data Stack Cabling Configurations	32
Data Stack Bandwidth and Partitioning Examples	33
Power-On Sequence for Switch Stacks	35
Mounting the Switch	36
Rack-Mounting	36
Attaching the Rack-Mount Brackets	37
Mounting the Switch in a Rack	39
Installing the Switch on a Table or Shelf	39
After Switch Installation	40
Connecting to the StackWise Ports	41
Connecting Devices to the Ethernet Ports	43
10/100/1000/Multigigabit Ethernet Port Connections	43
Auto-MDIX Connections	43
PoE and POE+ Port Connections	43

CHAPTER 4**Installing a Network Module 45**

	Installing a Network Module in the Switch	45
	Safety Warnings	45
	Installing a Network Module	46
	Removing a Network Module	49
	Finding the Network Module Serial Number	50
	Installing and Removing Pluggable Transceiver Modules	51
	Installing a Cisco Pluggable Transceiver Module	51
	Removing a Cisco Pluggable Transceiver Module	53
<hr/>		
CHAPTER 5	Installing a Power Supply Unit	55
	Power Supply Modules Overview	55
	Finding the Power Supply Module Serial Number	58
	Installation Guidelines	59
	Installing or Replacing an AC Power Supply Module	60
<hr/>		
CHAPTER 6	Installing a Fan Module	63
	Fan Modules Overview	63
	Installation Guidelines	64
	Installing a Fan Module	65
	Finding the Fan Module Serial Number	65
<hr/>		
CHAPTER 7	Configuring the Switch	67
	Configuring the Switch Using the Web User Interface	67
	Configuring the Switch Using the CLI	67
	Accessing the CLI Through the Console Port	67
	Connecting the RJ45 Console Port	67
	Connecting the USB Console Port	68
	Installing the Microsoft Windows USB Device Driver	69
	Installing the Cisco Microsoft Windows USB Driver	69
	Installing the Silicon Labs Windows USB Device Driver	70
	Uninstalling the Cisco Microsoft Windows USB Driver	70
	Uninstalling the Cisco Microsoft Windows USB Driver	70
<hr/>		
APPENDIX A	Technical Specifications	71

Environmental and Physical Specifications	71
Specifications for the Power Supplies and Fans	75

APPENDIX B

Switch LEDs	77
LEDs	77
Console LED	78
System LED	78
ACTIVE LED	78
STACK LED	79
PoE LED	80
Port LEDs and Modes	80
Beacon LED	83
RJ-45 Console Port LED	83
Fan LED	83
Uplink Port LEDs	83

Introduction	?
---------------------	----------



CHAPTER 1

Product Overview

- [Switch Models, on page 1](#)
- [Front Panel Components, on page 3](#)
- [Rear Panel, on page 9](#)
- [Network Configurations, on page 14](#)

Switch Models

The Cisco Catalyst 9200 Series switches have modular (C9200) and fixed (C9200L) switch models. The following tables describe all the available Cisco Catalyst 9200 Series switches and the features supported.

Table 1: C9200L Switch Models and Descriptions

Switch Model	Description
C9200L-24P-4G	Stackable 24x1G PoE+ ports; 4x1G SFP fixed uplink ports; 2 power supply slots; 2 fixed fans; supports StackWise-80.
C9200L-24P-4X	Stackable 24x1G PoE+ ports; 4x10G SFP+ fixed uplink ports; 2 power supply slots; 2 fixed fans; supports StackWise-80.
C9200L-24T-4G	Stackable 24x1G ports; 4x1G SFP fixed uplink ports; 2 power supply slots; 2 fixed fans; supports StackWise-80.
C9200L-24T-4X	Stackable 24x1G ports; 4x10G SFP+ fixed uplink ports; 2 power supply slots; 2 fixed fans; supports StackWise-80.
C9200L-48P-4G	Stackable 48x1G PoE+ ports; 4x1G SFP fixed uplink ports; 2 power supply slots; 2 fixed fans; supports StackWise-80.
C9200L-48P-4X	Stackable 48x1G PoE+ ports; 4x10G SFP+ fixed uplink ports; 2 power supply slots; 2 fixed fans; supports StackWise-80.
C9200L-48T-4G	Stackable 48x1G ports; 4x1G SFP fixed uplink ports; 2 power supply slots; 2 fixed fans; supports StackWise-80.
C9200L-48T-4X	Stackable 48x1G ports; 4x10G SFP+ fixed uplink ports; 2 power supply slots; 2 fixed fans; supports StackWise-80.

Switch Model	Description
C9200L-24PXG-4X	Stackable 8xMultigigabit Ethernet PoE+ ports and 16x1G PoE+ ports; 4x10G SFP+ fixed uplink ports; 2 power supply slots; 2 fixed fans; supports StackWise-80.
C9200L-24PXG-2Y	Stackable 8xMultigigabit Ethernet PoE+ ports and 16x1G PoE+ ports; 2x25G SFP28 fixed uplink ports; 2 power supply slots; 2 fixed fans; supports StackWise-80.
C9200L-48PXG-4X	Stackable 12xMultigigabit Ethernet PoE+ ports and 36x1G PoE+ ports; 4x10G SFP+ fixed uplink ports; 2 power supply slots; 2 fixed fans; supports StackWise-80.
C9200L-48PXG-2Y	Stackable 8xMultigigabit Ethernet PoE+ ports and 40x1G PoE+ ports; 2x25G SFP28 fixed uplink ports; 2 power supply slots; 2 fixed fans; supports StackWise-80.
C9200L-48PL-4G	Stackable 48x1G PoE+ ports with partial PoE support; 4x1G SFP fixed uplink ports; 2 power supply slots; 2 fixed fans; supports StackWise-80.
C9200L-48PL-4X	Stackable 48x1G PoE+ ports with partial PoE support; 4x10G SFP fixed uplink ports; 2 power supply slots; 2 fixed fans; supports StackWise-80.

Table 2: C9200 Switch Models and Descriptions

Switch Model	Description
C9200-24P	Stackable 24x1G PoE+ ports; 4x1G and 4x10G network modules for uplink ports; 2 power supply slots; 2 field-replaceable fans; supports StackWise-160.
C9200-24PB	Stackable 24x1G PoE+ ports; 4x1G and 4x10G network modules for uplink ports; 2 power supply slots; 2 field-replaceable fans; supports StackWise-160.
C9200-24T	Stackable 24x1G ports; 4x1G and 4x10G network modules for uplink ports; 2 power supply slots; 2 field-replaceable fans; supports StackWise-160.
C9200-48P	Stackable 48x1G PoE+ ports; 4x1G and 4x10G network modules for uplink ports; 2 power supply slots; 2 field-replaceable fans; supports StackWise-160.
C9200-48PB	Stackable 48x1G PoE+ ports; 4x1G and 4x10G network modules for uplink ports; 2 power supply slots; 2 field-replaceable fans; supports StackWise-160.
C9200-48T	Stackable 48x1G ports; 4x1G and 4x10G network modules for uplink ports; 2 power supply slots; 2 field-replaceable fans; supports StackWise-160.

Switch Model	Description
C9200-24PXG	Stackable 8 Multigigabit Ethernet and 16x1G PoE+ ports; supports 4x10G, 2x25G and 2x40G network modules for uplink ports; 2 power supply slots; 2 field-replaceable fans; supports StackWise-160.
C9200-48PXG	Stackable 8 Multigigabit Ethernet and 40x1G PoE+ ports; supports 4x10G, 2x25G and 2x40G network modules for uplink ports; 2 power supply slots; 2 field-replaceable fans; supports StackWise-160.
C9200-48PL	Stackable 48x1G PoE+ ports with partial PoE support; 4x1G and 4x10G network modules for uplink ports; 2 power supply slots; 2 field-replaceable fans; supports StackWise-160.

Front Panel Components

This section describes the front panel components of Cisco Catalyst 9200 Series switches :

- 24 or 48 downlink ports of one of the following types:
 - 10/100/1000
 - 10/100/1000 PoE+
- 1G/10G Uplink ports
- USB Type A storage ports
- USB mini-Type B console port
- LEDs
- Blue Beacon



Note The Cisco Catalyst 9200 Series switches might have slight cosmetic differences on the bezels.

Front Panel of a C9200L Switch

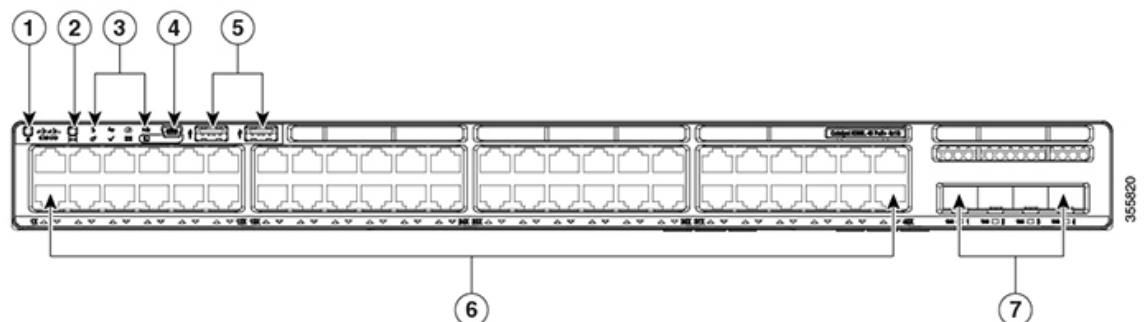

1	Blue Beacon (UID button)	5	USB Type A storage ports
2	Mode button	6	10/100/1000 PoE+ ports
3	Status LEDs	7	Fixed uplink ports
4	USB mini-Type B (console) port		

Front Panel of a C9200 Switch

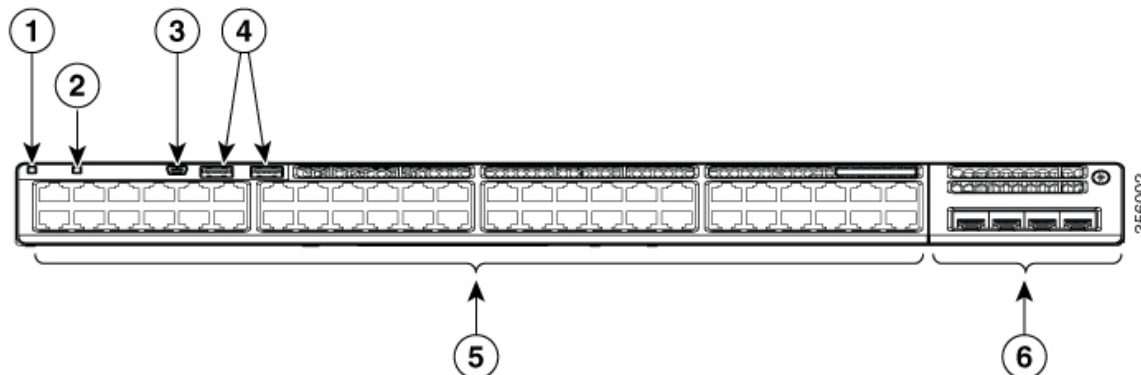

1	Blue Beacon (UID button)	4	USB Type A storage ports
2	Mode button	5	10/100/1000 PoE+ ports
3	USB mini-Type B (console) port	6	Network Module with uplink ports

10/100/1000 Ports

The 10/100/1000 ports use RJ-45 connectors with Ethernet pinouts. The maximum cable length is 328 feet (100 meters). The 100BASE-TX and 1000BASE-T traffic requires twisted pair (UTP) cable of Category 5 or higher. The 10BASE-T traffic can use Category 3 cable or higher.

PoE and PoE+ Ports

The PoE and PoE+ ports provide the following functionality:

- PoE/PoE+ ports: Support for IEEE 802.3af-compliant powered devices (up to 15.4W PoE per port) and support for IEEE 802.3at-compliant powered devices (up to 30W PoE+ per port).
- Support for pre-standard Cisco powered devices.
- Configurable support for Cisco intelligent power management, including enhanced power negotiation, power reservation, and per-port power policing.

See the [Power Supply Modules, on page 11](#) for the power supply matrix that defines the available PoE and PoE+ power per port. The PoE circuit has been evaluated to meet the limits for Limited Power Source (LPS) per Annex Q in IEC/UL 62368-1. It has also been evaluated as a class ES1, PS2.

Multigigabit Ethernet Ports

The Multigigabit (mGig) Ethernet ports can be configured to auto-negotiate multiple speeds on switch ports. The ports support 100 Mbps, 1 Gbps, 2.5 Gbps, and 5 Gbps speeds on Category 5e (Cat5e) cables, and up to 10 Gbps over Category 6 (Cat6) and Category 6A (Cat6A) cables up to a maximum of 100 m. 10Gbps over Cat6 cable is limited for distances up to 55 m. For 10GBASE-T, Cat6a can support up to 100 m when transmitting 10Gbps. Due to the extra bandwidth requirements from the cable, additional limitations exist for best performance. These limitations include, but are not limited to cable reach, cable bundling parameters (tightness, frequency, number of cables, speed with respect to each cable) and cable termination quality.

The 802.3 channel requirements for interoperability typically limit the cable reach to 100 m, but other factors can shorten this reach. In addition, for both Cisco UPOE and Cisco UPOE+ and data integrity, the 100 m total should not include more than 10 m total stranded or patch cable. Therefore, it is assumed that a 100 m link includes a maximum of two 5 m patch cables of the appropriate category, and 90 m of plenum or riser (i.e. solid copper core) cables. Ensure that you follow the TIA guidance on cable dressing.

It is recommended to test the complete link using an appropriate cable tester for 10 Gbps as well as 5 Gbps links. However, even if the link passes cable testing, it is still prone to occasional errors due to aggressors in the bundle, and physical disturbances of the cables. As an example of bundling limitations, for 5 Gbps with cat5e cable, only a total 45 m bundled length is supported; the remaining 55 m should be unbundled. For bundling, follow [Cisco Guidelines and Best Practices for the Installation and Maintenance of Data Networking Equipment](#) which recommends the use of Velcro ties every 1 to 2 m for bundled sections.

If you are upgrading the network gear but reusing the existing cable plant, note that at speeds above 2.5 Gbps traditional Cat5e channel specifications do not support full 100 m reach. To ensure 5 Gbps link speeds, we recommend using Cat6a cabling. For more information, see the Whitepaper from NBASE-T alliance, which has now merged with Ethernet Alliance, archived at <https://archive.nbaset.ethernetalliance.org/library/white-paper-2/>.



Note Multigigabit ports do not support half duplex mode. Use full duplex mode.

Management Ports

The management ports connect the switch to a PC running Microsoft Windows or to a terminal server.

- Ethernet management port. See [Ethernet Management Port, on page 14](#).
- RJ-45 console port (EIA/TIA-232). See [RJ-45 Console Port, on page 14](#).
- USB mini-Type B console port (5-pin connector).

The 10/100/1000 Ethernet management port connection uses a standard RJ-45 crossover or straight-through cable. The RJ-45 console port connection uses the supplied RJ-45-to-DB-9 female cable. The USB console port connection uses a USB Type A to 5-pin mini-Type B cable. The USB console interface speeds are the same as the RJ-45 console interface speeds.

If you use the USB mini-Type B console port, the Cisco Windows USB device driver must be installed on any PC connected to the console port (for operation with Microsoft Windows). Mac OS X or Linux do not require special drivers.

The 4-pin mini-Type B connector resembles the 5-pin mini-Type B connectors. They are not compatible. Use only the 5-pin mini-Type B.

Figure 1: USB Mini-Type B Port

This illustration shows a 5-pin mini-Type B USB port.

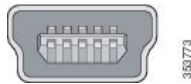

With the Cisco Windows USB device driver, you can connect and disconnect the USB cable from the console port without affecting Windows HyperTerminal operations.

The console output always goes to both the RJ-45 and the USB console connectors, but the console input is active on only one of the console connectors at any one time. The USB console takes precedence over the RJ-45 console. When a cable is connected into the USB console port, the RJ-45 console port becomes inactive. Conversely, when the USB cable is disconnected from the USB console port, the RJ-45 port becomes active.

You can use the command-line interface (CLI) to configure an inactivity timeout which reactivates the RJ-45 console if the USB console has been activated and no input activity has occurred on the USB console for a specified time.

After the USB console deactivates due to inactivity, you cannot use the CLI to reactivate it. Disconnect and reconnect the USB cable to reactivate the USB console. For information on using the CLI to configure the USB console interface, see the Software Configuration Guide.

USB Type A Port

The USB Type A port provides access to external USB flash devices (also known as thumb drives or USB keys).

The port supports Cisco USB flash drives with capacities from 128 MB to 8 GB. USB devices with port densities of 128 MB, 256 MB, 1 GB, 4 GB, and 8 GB are supported. When combined with stacking, you can upgrade other switches in the stack from an USB key inserted in any switch within the stack. Cisco IOS software provides standard file system access to the flash device: read, write, erase, and copy, as well as the ability to format the flash device with a FAT file system.

It provides you with the ability to automatically upgrade the internal flash with the USB drive's configuration and image for emergency switch recovery using USB auto-upgrade. This feature checks the internal flash for a bootable image and configuration and if either image or the configuration is not available, then the USB drive is checked for boot images and configuration. If the boot image and configuration are available, these are copied to flash for the reboot.

SD Card Slot

Cisco Catalyst 9200CX compact switches support an SD (Secure Digital) Card that extends the onboard flash storage memory on the switch.

The SD card can be used instead of the internal flash memory of the switch to update or restore configuration settings. Additionally, the SD card can be used to boot the switch. You can boot a switch from its internal flash memory or from an SD card; SD card takes precedence over internal flash memory. You can also copy

IOS software and switch configuration settings from a PC or from the switch to the SD card, and then use the SD card to copy this software and settings to other switches.

You can access an SD card using the switch boot loader or the command prompt.

Figure 2: SD Card Slot

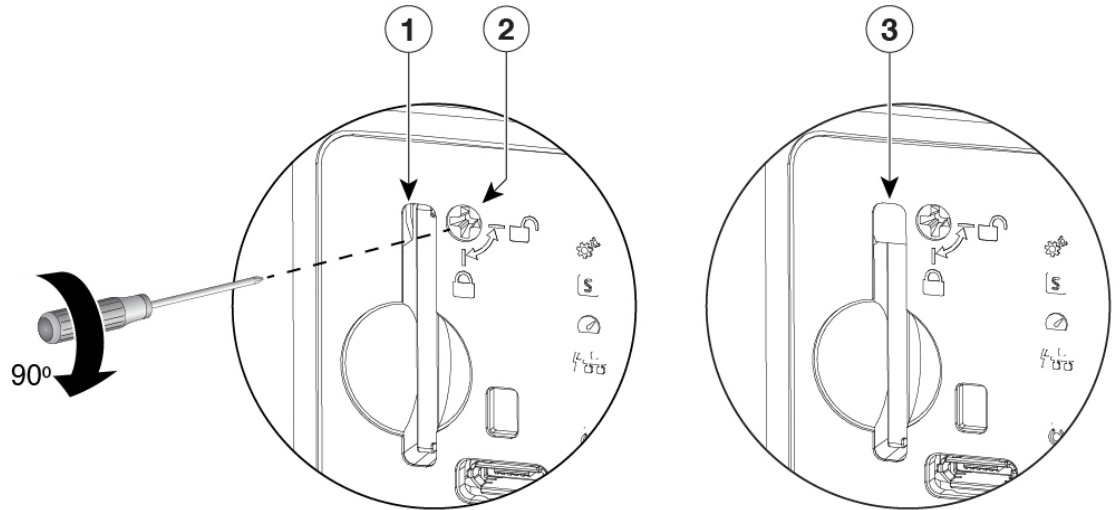

357863

1	SD Card slot in unlocked position	3	SD Card slot in locked position
2	SD lock	<p>Note Carefully rotate the SD lock at 90° to lock or unlock the SD card slot. Do not apply excessive pressure while rotating the lock to the extreme end, to prevent it from damaging the lock.</p>	

Uplink Ports

The Cisco Catalyst 9200 Series switches support both fixed uplinks and modular uplinks. The C9200 switch models support modular uplinks with one hot-swappable network module that provides uplink ports to connect to other devices.

The fixed uplink ports on C9200L switch models support the following types of transceiver modules.

- 4x1G ports that support 1G SFP modules.
- 4x10G ports that support either 1G SFP or 10G SFP+ modules.
- 2x25G ports that support SFP28 modules.

For supported Cisco pluggable transceiver modules (SFP, SFP, SFP28 and QSFP+ modules), refer to the Cisco Transceiver Modules Compatibility Information at

http://www.cisco.com/en/US/products/hw/modules/ps5455/products_device_support_tables_list.html



Note For information about installing an (uplink) transceiver module, see [Installing a Cisco Pluggable Transceiver Module, on page 51](#).

Figure 3: Network Module C9200-NM-4G

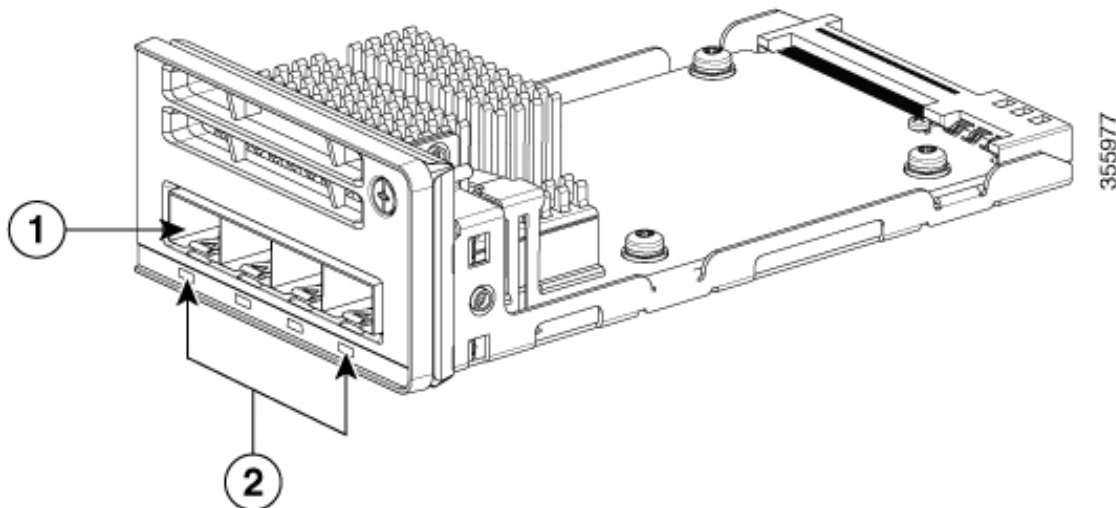

1 Module slot	2 LEDs
---------------	--------

The following table lists the optional Cisco Catalyst 9200 Series Switches uplink network modules with 4x1G, 4x10G, 2x25G, and 2x40G slots.

Table 3: Supported Network Modules

Network Module	Description
C9200-NM-4G	This module has four 1G SFP module slots. Any combination of standard SFP modules is supported. SFP+ modules are not supported. If you insert an SFP+ module in the 1G network module, the SFP+ module does not operate, and the switch logs an error message. This module is not supported on C9200 Multigigabit Ethernet switches.
C9200-NM-4X	This module has four 10G SFP module slots. Each port supports a 1G or 10G connection. Any combination of standard SFP modules is supported. This module is supported on both 1G and Multigigabit Ethernet switch models of C9200 switches.
C9200-NM-2Y	This module has two 25 Gigabit Ethernet SFP28 module slots. Any combination of SFP, SFP+, and SFP28 modules are supported. This module is supported only on C9200 Multigigabit Ethernet switches.

Network Module	Description
C9200-NM-2Q	This module has two 40G slots with a QSFP+ connector in each slot. This module is supported only on C9200 Multigigabit Ethernet switches.
C9200-NM-BLANK	Insert this blank module when the switch has no uplink ports to enable sufficient airflow.



Note For information about installing a network module, see [Installing a Network Module, on page 46](#).

Rear Panel

The switch rear panel includes StackWise connectors, fan modules, and power supply modules.

Figure 4: Rear Panel of a C9200L Switch

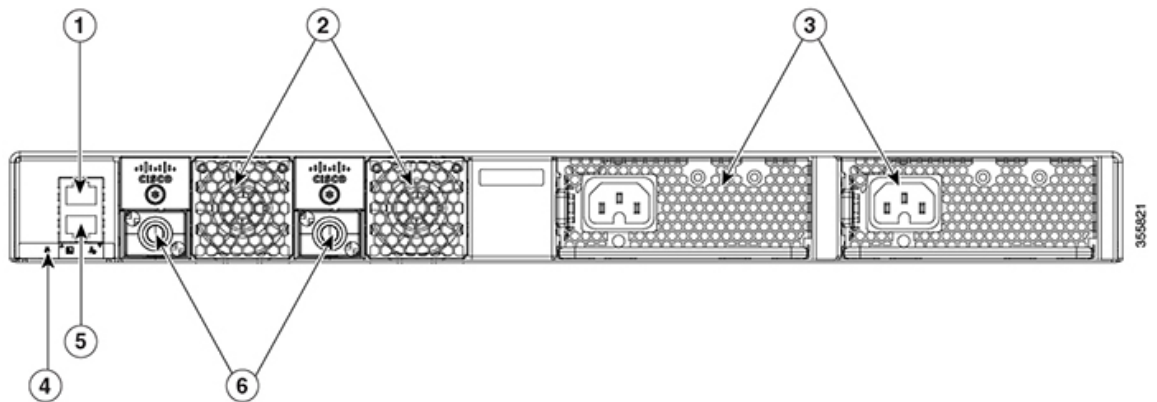

1	RJ-45 console port	4	Blue Beacon LED
2	Fixed fan modules on C9200L switches	5	MGMT (RJ-45 10/100/1000 management port)
3	Power supply module slots	6	StackWise-80 port connectors

Figure 5: Rear Panel of a C9200 Switch

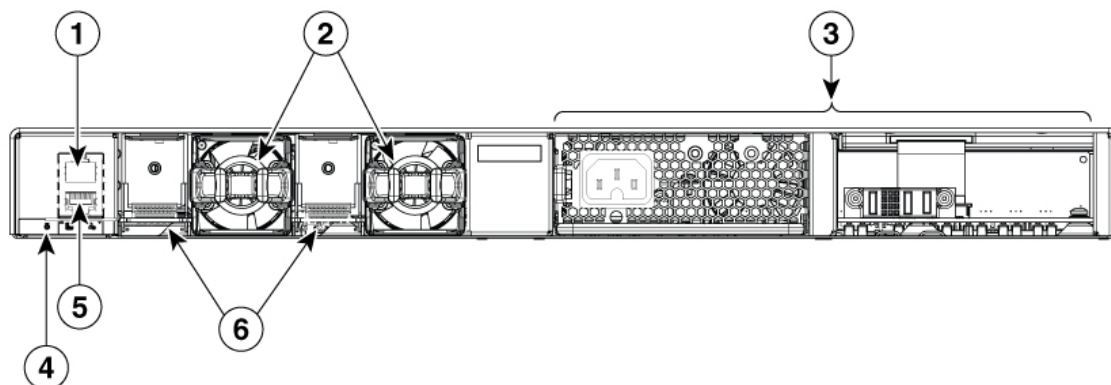

356001

1	RJ-45 console port	4	Blue Beacon LED
2	Modular fan modules on C9200 switches	5	MGMT (RJ-45 10/100/1000 management port)
3	Power supply module slots	6	StackWise-160 port connector slots with stack blanks installed

RFID Tag

The switch has a built-in, front-facing, passive RFID tag that uses UHF RFID technology and requires an RFID reader with compatible software. It provides auto-identification capabilities for asset management and tracking. The RFID tags are compatible with the Generation 2 GS1 EPC Global Standard and are ISO 18000-6C compliant. They operate in the 860- to 960-MHz UHF band. For more information, see [Radio Frequency Identification \(RFID\) on Cisco Catalyst 9000 Family Switches White Paper](#).

StackWise Ports

StackWise ports are used to connect switches in StackWise stacking configurations. The switch ships with a 0.5-meter StackWise cable that you can use to connect the StackWise ports. For more information on StackWise cables, see [Connecting to the StackWise Ports, on page 41](#).



Caution Use only approved cables, and connect only to similar Cisco equipment. Equipment might be damaged if connected to nonapproved Cisco cables or equipment.

Auxiliary Power Adapter

C9200CX-12T-2X2G switches can be powered either through the 1G copper uplink port connected to a PoE PSE port capable of providing IEEE 802.3bt Class 6 power or through an auxiliary AC-DC(PWR-ADPT) or DC-DC(C9K-ADPT-DC) power adapter. If the switch has both PD power and auxiliary power adapter connected, the auxiliary power takes precedence over PD power and the PD port gets disabled. If both are

connected and the auxiliary power source is removed, the switch resets for the PD to perform detection and classification before providing power to the system.

You can order the power adapter with the switch, or you can order it later from your Cisco representative.

Power Supply Modules

The switch has a field replaceable main AC power supply module and a redundant hot-swappable field replaceable AC power supply module. The switch is powered through one or two internal power supply modules. In switches with PoE capability, the redundant power supply can also be used for extra PoE power.

Following are the power supply modules supported on Cisco Catalyst 9200 Series Switches:

- PWR-C5-125WAC
- PWR-C5-600WAC
- PWR-C5-1KWAC
- PWR-C6-125WAC
- PWR-C6-600WAC
- PWR-C6-1KWAC

The switch has two internal power supply module slots. You can use two AC power supply modules or one power supply module and a blank module (PWR-C5-BLANK).

The switch can operate with either one or two active power supply modules.

[Switch Models, on page 1](#) shows the default power supply modules that ship with each switch model. All power supply modules (except the blank modules) have internal fans. All switches ship with a blank power supply module in the second power supply slot. Each AC power supply module has a power cord (CAB-TA-XXX) for connection to an AC power outlet.



Caution Do not operate the switch with one power supply module slot empty. For proper chassis cooling, both power supply module slots must be populated with either a power supply or a blank module.

The power supply modules are autoranging units that support input voltages between 100 and 240 VAC. The output voltage range is 12 to 12.5 V for 125W power supply and 54 to 56 V for 600W and 1000W power supplies.

All the PoE-enabled switches when installed with both the power supplies support full PoE+; 1440W on a 48-port switch and 740W on a 24-port switch. The partial PoE-enabled switches support only 600W power supply providing a PoE budget of 370W. If the switch is installed with one power supply, the available POE budget is 370W and 740W, if there are two power supplies installed.

The following tables show the PoE available and PoE requirements for PoE switch models.

Table 4: Available PoE with AC Power Supply

Models	Default Power Supply	Available PoE	Full PoE with Redundant Power Supply
C9200 Switches			

Models	Default Power Supply	Available PoE	Full PoE with Redundant Power Supply
C9200-24P	PWR-C5-600WAC or PWR-C6-600WAC	370W	740W
C9200-48P	PWR-C5-1KWAC or PWR-C6-1KWAC	740W	1440W
C9200-24T	PWR-C5-125WAC or PWR-C6-125WAC	-	-
C9200-48T	PWR-C5-125WAC or PWR-C6-125WAC	-	-
C9200-24PB	PWR-C5-600WAC or PWR-C6-600WAC	370W	740W
C9200-48PB	PWR-C5-1KWAC or PWR-C6-1KWAC	740W	1440W
C9200-48PL	PWR-C5-600WAC or PWR-C6-600WAC	370W	740W
C9200-24PXG	PWR-C5-600WAC or PWR-C6-600WAC	370W	740W
C9200-48PXG	PWR-C5-1KWAC or PWR-C6-1KWAC	740W	1440W
C9200L Switches			
C9200L-24P-4G	PWR-C5-600WAC	370W	740W
C9200L-24P-4X	PWR-C5-600WAC	370W	740W
C9200L-24PXG-2Y	PWR-C5-600WAC	370W	740W
C9200L-24PXG-4X	PWR-C5-600WAC	370W	740W
C9200L-24T-4G	PWR-C5-125WAC	—	—
C9200L-24T-4X	PWR-C5-125WAC	—	—
C9200L-48P-4G	PWR-C5-1KWAC	740W	1440W
C9200L-48P-4X	PWR-C5-1KWAC	740W	1440W
C9200L-48PL-4G	PWR-C5-600WAC	370W	740W
C9200L-48PL-4X	PWR-C5-600WAC	370W	740W
C9200L-48PXG-2Y	PWR-C5-1KWAC	740W	1440W
C9200L-48PXG-4X	PWR-C5-1KWAC	740W	1440W

Models	Default Power Supply	Available PoE	Full PoE with Redundant Power Supply
C9200L-48T-4G	PWR-C5-125WAC	—	—
C9200L-48T-4X	PWR-C5-125WAC	—	—

The power supply modules have two status LEDs.

Table 5: Switch Power Supply Module LEDs

→]	Description	←]	Description
Off	No AC input power.	Off	Output is disabled, or input is outside operating range (AC LED is off).
Green	AC input power present.	Green	Power output to switch active.
		Red	Output has failed.

Fan Modules

The Cisco Catalyst 9200 Series Switches supports two internal fixed 12-V fan modules and two field-replaceable fan modules (C9200-FAN=). The C9200 models support modular fans whereas the C9200L models provide two internal fixed fans.

For information about the type of fan module supported on different switch models, see [Switch Models, on page 1](#).

The air circulation system consists of the fan modules and the power supply modules. The airflow patterns vary depending on the power supply configuration. The switch can operate at ambient temperature if one of the fans fail.

Figure 6: Switch Airflow Pattern

The following illustration shows the airflow pattern for the switches. The blue arrow shows cool airflow, and the red arrow shows warm airflow.

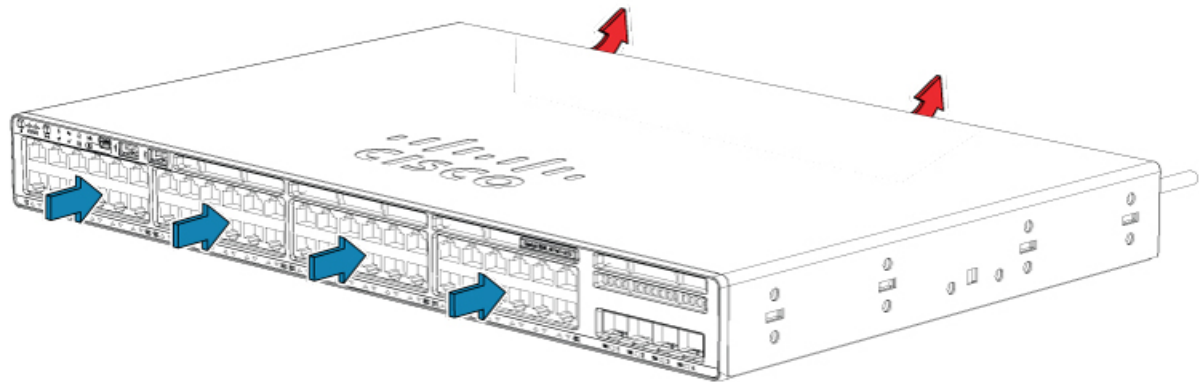

Ethernet Management Port

You can connect the switch to a host such as a Windows workstation or a terminal server through the 10/100/1000 Ethernet management port or one of the console ports. The 10/100/1000 Ethernet out-of-band management port is a virtual routing and forwarding (VRF) interface and uses a RJ-45 crossover or straight-through cable.



Note The 10/100/1000 Ethernet management port is an RJ-45 connector that should be connected to a Windows workstation or a terminal server. Do not connect this port to another port in the same switch or to any port within the same switch stack.

The following table shows the Ethernet management port LED colors and their meanings.

Table 6: Ethernet Management Port LED

Color	Description
Green	Link up but no activity.
Blinking green	Link up and activity.
Off	Link down.

RJ-45 Console Port

The RJ-45 console port connection uses the supplied RJ-45-to-DB-9 female cable.

The following table shows the RJ-45 console port LED colors and their meanings.

Table 7: RJ-45 Console LED

Color	Description
Green	RJ-45 console port is active.
Off	The port is not active.

Network Configurations

See the switch software configuration guide for network configuration concepts and examples of using the switch to create dedicated network segments and interconnecting the segments through Fast Ethernet and Gigabit Ethernet connections.



CHAPTER 2

Preparing for Installation

- [Safety Warnings, on page 15](#)
- [Installation Guidelines, on page 17](#)
- [Site Requirements, on page 18](#)
- [Tools and Equipment, on page 27](#)
- [Verifying Switch Operation, on page 28](#)

Safety Warnings

This section includes the basic installation caution and warning statements. Read this section before you start the installation procedure. Translations of the warning statements appear in the Regulatory Compliance and Safety Information guide on Cisco.com.



Warning Before working on equipment that is connected to power lines, remove jewelry (including rings, necklaces, and watches). Metal objects will heat up when connected to power and ground and can cause serious burns or weld the metal object to the terminals. Statement 43



Warning Do not stack the chassis on any other equipment. If the chassis falls, it can cause severe bodily injury and equipment damage. Statement 48



Warning Ethernet cables must be shielded when used in a central office environment. Statement 171



Warning Read the wall-mounting instructions carefully before beginning installation. Failure to use the correct hardware or to follow the correct procedures could result in a hazardous situation to people and damage to the system. Statement 378



Warning Do not work on the system or connect or disconnect cables during periods of lightning activity. Statement 1001



Warning Read the installation instructions before connecting the system to the power source. Statement 1004



Warning To prevent bodily injury when mounting or servicing this unit in a rack, you must take special precautions to ensure that the system remains stable. The following guidelines are provided to ensure your safety:

- This unit should be mounted at the bottom of the rack if it is the only unit in the rack.
- When mounting this unit in a partially filled rack, load the rack from the bottom to the top with the heaviest component at the bottom of the rack.
- If the rack is provided with stabilizing devices, install the stabilizers before mounting or servicing the unit in the rack.

Statement 1006



Warning Class 1 laser product. Statement 1008



Warning This unit is intended for installation in restricted access areas. A restricted access area can be accessed only through the use of a special tool, lock and key, or other means of security. Statement 1017



Warning The plug-socket combination must be accessible at all times, because it serves as the main disconnecting device. Statement 1019



Warning Use copper conductors only. Statement 1025



Warning This unit might have more than one power supply connection. All connections must be removed to de-energize the unit. Statement 1028



Warning Only trained and qualified personnel should be allowed to install, replace, or service this equipment. Statement 1030



Warning Ultimate disposal of this product should be handled according to all national laws and regulations. Statement 1040



Warning To prevent the system from overheating, do not operate it in an area that exceeds the maximum recommended ambient temperature of: <113°F (45°C). Statement 1047



Warning This warning symbol means danger. You are in a situation that could cause bodily injury. Before you work on any equipment, be aware of the hazards involved with electrical circuitry and be familiar with standard practices for preventing accidents. Use the statement number provided at the end of each warning to locate its translation in the translated safety warnings that accompanied this device. Statement 1071



Warning Voltages that present a shock hazard may exist on Power over Ethernet (PoE) circuits if interconnections are made using uninsulated exposed metal contacts, conductors, or terminals. Avoid using such interconnection methods, unless the exposed metal parts are located within a restricted access location and users and service people who are authorized within the restricted access location are made aware of the hazard. A restricted access area can be accessed only through the use of a special tool, lock and key or other means of security. Statement 1072



Warning No user-serviceable parts inside. Do not open. Statement 1073



Warning Installation of the equipment must comply with local and national electrical codes. Statement 1074



Warning To prevent airflow restriction, allow clearance around the ventilation openings to be at least: 3 inches (7.6 cm). Statement 1076



Warning Hot surface. Statement 1079

Installation Guidelines

When determining where to install the switch, verify that these guidelines are met:

- Clearance to the switch front and rear panel meets these conditions:
 - Front-panel LEDs can be easily read.

- Access to ports is sufficient for unrestricted cabling.
- AC power cord can reach from the AC power outlet to the connector on the switch rear panel.
- The SFP/SFP+ module minimum bend radius and connector length is met. See the SFP/SFP+ module documentation for more information.
- Cabling is away from sources of electrical noise, such as radios, power lines, and fluorescent lighting fixtures. Make sure that the cabling is safely away from other devices that might damage the cables.
- Make sure power-supply modules and fan modules are securely inserted in the chassis before moving the switch.
- Airflow around the switch and through the vents is unrestricted. For more information, see [Air Flow](#).
- For copper connections on Ethernet ports, cable lengths from the switch to connected devices can be up to 328 feet (100 meters).
- Temperature around the unit does not exceed 113°F (45°C). If the switch is installed in a closed or multirack assembly, the temperature around it might be greater than normal room temperature. For more information, see [Temperature](#).
- Humidity around the switch does not exceed 95 percent. For more information, see [Humidity](#).
- Altitude at the installation site is not greater than 10,000 feet. For more information, see [Altitude](#).
- Cooling mechanisms, such as fans and blowers in the switch, can draw dust and other particles causing contaminant buildup inside the chassis, which can result in system malfunction. You must install this equipment in an environment as free from dust and foreign conductive material (such as metal flakes from construction activities) as possible. For more information, see [Air Quality](#) and [Corrosion](#).

For more information on choosing a location for the switch installation, see [Site Requirements](#).



Note The illustrations used in this section shows a C9200L switch. The C9200 switch installation is similar to C9200L, follow the same steps for installing C9200 switches.

Site Requirements

Planning a proper location for the switch and layout of the equipment rack or wiring closet is essential for successful system operation. These sections describe some of the basic site requirements that you should be aware of as you prepare to install your switch, including the following:

- Environmental factors can adversely affect the performance and longevity of your system.
- Install the switch in an enclosed, secure area, ensuring that only qualified personnel have access to the switch and control of the environment.
- Equipment that is placed too closely together or that is inadequately ventilated may cause system over-temperature conditions, leading to premature component failure.
- Poor equipment placement can make chassis panels inaccessible and difficult to maintain.
- The switch requires a dry, clean, well-ventilated, and air-conditioned environment.

- To ensure normal operation, maintain ambient airflow. If the airflow is blocked or restricted, or if the intake air is too warm, an over-temperature condition may occur. The switch environmental monitor may then shut down the system to protect the system components.
- Multiple switches can be rack mounted with little or no clearance above and below the chassis. However, when mounting a switch in a rack with other equipment, or when placing it on the floor near other equipment, ensure that the exhaust from other equipment does not blow into the air intake vent of the switch chassis.

Temperature

Temperature extremes may cause a system to operate at reduced efficiency and cause a variety of problems, including premature aging and failure of chips, and failure of mechanical devices. Extreme temperature fluctuations may also cause chips to become loose in their sockets. Observe the following guidelines:

- Ensure that the chassis has adequate ventilation.
- Do not place the chassis within a closed-in wall unit or on top of cloth, which can act as insulation.
- Do not place the chassis where it will receive direct sunlight, particularly in the afternoon.
- Do not place the chassis next to a heat source of any kind, including heating vents.
- Adequate ventilation is particularly important at high altitudes. Make sure that all the slots and openings on the system remain unobstructed, especially the fan vent on the chassis.
- Clean the installation site at regular intervals to avoid buildup of dust and debris, which may cause a system to overheat.
- If system is exposed to abnormally low temperatures, allow a two hour warm up period, in ambient temperature no lower than 32°F (0 °C) before turning on.

Failure to observe these guidelines may damage the chassis' internal components.

Air Flow

The switch is designed to be installed in an environment where there is a sufficient volume of air available to cool the supervisor engines, modules, and power supplies. If there are any constraints with regard to the free flow of air through the chassis, or if the ambient air temperature is elevated, the switch environmental monitor may then shut down the system to protect the system components.

To maintain proper air circulation through the switch chassis, we recommend that you maintain a minimum space of 6 inches (15 cm) between a wall and the chassis and power supply unit air intakes or a wall and the chassis and power supply unit hot air exhausts. In situations where the switch chassis are installed in adjacent racks, you should allow a minimum space of 12 inches (30.5 cm) between the air intake of one chassis and the hot air exhaust of another chassis. Failure to maintain adequate spacing between chassis may cause the switch chassis that is drawing in the hot exhaust air to overheat and fail.

If you are installing your switch in an enclosed or partially enclosed rack, we strongly recommend that you verify that your site meets the following guidelines:

- Verify that the ambient air temperature within the enclosed or partially enclosed rack is within the chassis operating temperature limits. After installing the chassis in the rack, power up the chassis and allow the chassis temperature to stabilize (approximately 2 hours).

Measure the ambient air temperature at the chassis air intake grill by positioning an external temperature probe 1 inch (2.5 cm) away from the chassis left side, and centered on the chassis both horizontally and vertically.

Measure the ambient air temperature at the power supply unit air intake grill by positioning an external temperature probe 1 inch (2.5 cm) away from the chassis front, centered on the power supply unit section located above the card slots.

- If the ambient intake air temperature is less than 109°F (45°C) at altitudes of 6,000 feet and below, the rack meets the intake air temperature criterion. At altitudes above that threshold and up to 10,000 feet (3000 m), the air intake should not exceed 104°F (40°C).
- If the ambient intake air temperature exceeds this recommendation, the system may experience minor temperature alarms and increase fan speeds in response.
- If the ambient intake air temperature equals or is greater than 131°F (55°C), the system may experience a major temperature alarm with maximum fan speeds in response. If ambient temperature continues to increase, system will respond with protective shut down.
- Plan ahead. A switch that is currently installed in an enclosed or partially enclosed rack might meet ambient air temperature and air flow requirements at present. However, if you add more chassis to the rack or more modules to a chassis in the rack, the additional heat generated might cause the ambient air temperature at the chassis or power supply unit inlets to exceed recommended conditions which may trigger thermal alarms.

If installation conditions for inlet temperature and airflow are marginal or not fully met, activate the fan tray's NEBS mode, which has more aggressive programming to address restricted spacing and elevated ambient temperatures. This should result in reduced thermal alarms along with greater acoustic noise and increased power consumption associated with higher fan speeds.

Humidity

High-humidity conditions may cause moisture to enter the system, and cause corrosion of internal components and degradation of properties such as electrical resistance, thermal conductivity, physical strength, and size. Extreme moisture buildup inside the system may result in electrical short circuit, which may cause serious damage to the system. Each system is rated for storage and operation in 10 to 95 percent relative humidity, non-condensing with a humidity gradation of 10 percent per hour. Buildings in which climate is controlled by air-conditioning in the warmer months and by heat during the colder months usually maintain an acceptable level of humidity for system equipment. However, if a system is located in an unusually humid location, a dehumidifier should be used to maintain the humidity within an acceptable range.

Altitude

Operating a system at high altitude (low pressure) reduces the efficiency of forced and convection cooling and may result in electrical problems related to arcing and corona effects. This condition may also cause sealed components with internal pressure, such as electrolytic capacitors, to fail or perform at reduced efficiency.

Dust and Particles

Fans cool power supplies and system components by drawing in room-temperature air and exhausting heated air out through various openings in the chassis. However, fans also ingest dust and other particles, causing

contaminant buildup in the system and increased internal chassis temperature. A clean operating environment can greatly reduce the negative effects of dust and other particles, which act as insulators and interfere with the mechanical components in the system.

The standards listed below provide guidelines for acceptable working environments and acceptable levels of suspended particulate matter:

- National Electrical Manufacturers Association (NEMA) Type 1
- International Electrotechnical Commission (IEC) IP-20

Air Quality

Dust is everywhere and often invisible to the naked eye. It consists of fine particles in the air that originate from various sources, such as soil dust lifted by weather, from volcanic eruptions, or pollution. Dust at an installation site may contain small amounts of textile, paper fibers, or minerals from outdoor soil. It may also contain natural contaminants, such as chlorine from the marine environment and industrial contaminants such as sulfur. Ionized dust and debris are dangerous and get attracted to electronic equipment.

The accumulation of dust and debris on electronic equipment has the following adverse effects:

- It increases the operating temperature of the equipment. According to the Arrhenius effect, an increase in the operating temperature leads to a decrease in reliability and life of the equipment.
- The moisture and corrosive elements that are present in the dust can corrode the electronic or mechanical components and cause premature board failure.

These adverse effects are further accelerated by the presence of fans in the data networking equipment that ingest dust and other particles into the equipment. Higher the volume of air that is generated by the fans for cooling, the higher the quantity of dust and particulates that get deposited and trapped inside the equipment. Remove or minimize the presence of dust and particulates at the installation site by following the guidelines mentioned in ANSI 71-04-2013 regulations.



Note In addition to the guidelines mentioned in ANSI 71-04-2013 regulations, follow all applicable guidelines as per site conditions to remove or minimize other contaminants.

Corrosion

Corrosion is a chemical reaction that occurs between electronic components and gases which results in metal deterioration. Corrosion attacks edge connectors, pin connectors, IC plug-in sockets, wirewraps, and all other metal components. Depending on the type and concentration level of the corrosive gases, performance degradation of the components occurs either rapidly or over a period of time. It also leads to blocked currents, brittle connection points, and overheated electrical systems. Corrosion by-products form insulating layers on circuits and causes electronic failure, short circuits, pitting, and metal loss.

A type of corrosion known as creep corrosion, that primarily affects PCBA (Printed Circuit Board Assembly) occurs when the PCBA is subjected to a harsh, and sulfur-rich (hydrogen sulfide) end-use environment over a prolonged period of time. The corrosion begins on certain exposed metals, such as copper and silver, and then creeps along the remaining metal surface either causing electrical short circuits or creating holes. Creep corrosion also occurs on electronic components such as resistors and PCBs.

To prevent corrosion, remove or minimize the presence of dust and particulates at the installation site by following the guidelines mentioned in ANSI 71-04-2013 regulations.

Figure 7: A PCB with Corrosion on its Metal Contacts

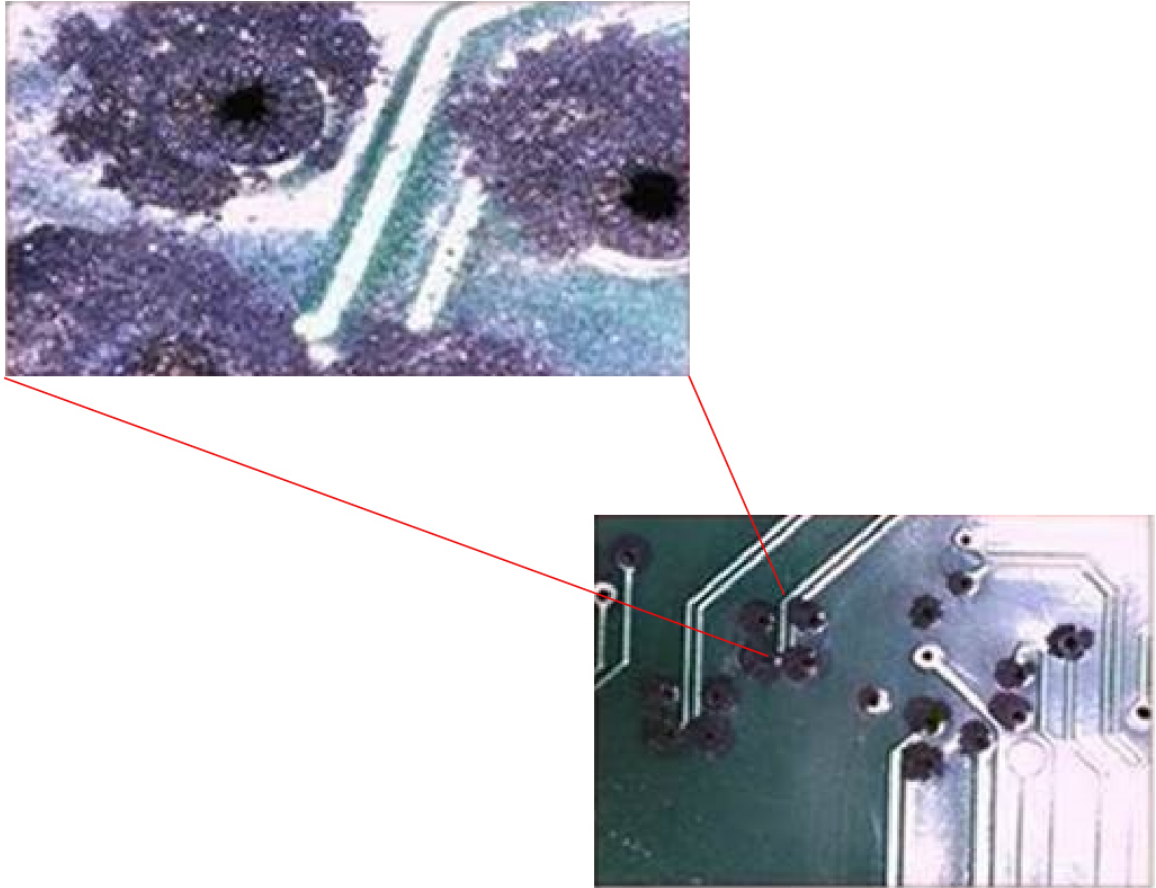

EMI and Radio Frequency Interference

Electro-Magnetic interference (EMI) and radio frequency interference (RFI) from a system can adversely affect devices such as radio and television (TV) receivers operating near the system. Radio frequencies emanating from a system can also interfere with cordless and low-power telephones. Conversely, RFI from high-power telephones can cause spurious characters to appear on the system monitor. RFI is defined as any EMI with a frequency above 10 kilohertz (kHz). This type of interference can travel from the system to other devices through the power cable and power source, or through the air in the form of transmitted radio waves. The Federal Communications Commission (FCC) publishes specific regulations to limit the amount of harmful interference emitted by computing equipment. Each system meets these FCC regulations. To reduce the possibility of EMI and RFI, follow these guidelines:

- Always operate the system with the chassis covers installed.
- Ensure that all chassis slots are covered by a metal filler bracket and that an unused power supply bay has a metal cover plate installed.
- Ensure that the screws on all peripheral cable connectors are securely fastened to their corresponding connectors on the back of the chassis.

- Always use shielded cables with metal connector shells for attaching peripherals to the system.

When wires are run for any significant distance in an electromagnetic field, interference can occur between the field and the signals on the wires. This fact has two implications for the construction of plant wiring:

- Bad wiring practice can result in radio interference emanating from the plant wiring.
- Strong EMI, especially when it is caused by lightning or radio transmitters, can destroy the signal drivers and receivers in the chassis, and even create an electrical hazard by conducting power surges through lines into equipment.



Note To predict and provide a remedy for strong EMI, consult experts in RFI.

If you use twisted-pair cable in your plant wiring, include a good distribution of grounding conductors to reduce EMI. If you exceed the recommended distances, use a high-quality twisted-pair cable with one ground conductor for each data signal when applicable.

If the wires exceed the recommended distances, or if wires pass between buildings, give special consideration to the effect of a lightning strike in your vicinity. The electromagnetic pulse caused by lightning or other high-energy phenomena can easily couple enough energy into unshielded conductors to destroy electronic devices. If you have had problems of this sort in the past, you may want to consult experts in electrical surge suppression and shielding.



Warning The intra-building ports (Copper Based Ethernet Ports) of the equipment or subassembly is suitable for connection to inside a building or unexposed wiring or cabling only. If the intra-building ports of the equipment or subassembly is metallically connected to interfaces that connect to the Out Side Plant (OSP) or its wiring, the metallic-connection **MUST NOT** be more than 6 meters (approximately 20 feet). These interfaces are designed for use as intra-building interfaces only (Type 2, 4, or 4a ports as described in GR-1089-CORE) and require isolation from the exposed OSP cabling. The addition of Primary Protectors is not sufficient protection in order to connect these interfaces metallically to an OSP wiring system.

Shock and Vibration

The equipment complies with the Earthquake, Office, and Transportation Vibration, and Equipment Handling Criteria of GR-63-CORE.

Power Source Interruptions

Systems are especially sensitive to variations in voltage supplied by the AC power source. Overvoltage, undervoltage, and transients (or spikes) can erase data from memory or even cause components to fail. To protect against these types of problems, power wiring ground conductors should always be properly grounded. Also, place the system on a dedicated power circuit (rather than sharing a circuit with other heavy electrical equipment). In general, do not allow the system to share a circuit with any of the following:

- Copy machines
- Air conditioners

- Vacuum cleaners
- Space heaters
- Power tools
- Teletype machines
- Laser printers
- Facsimile machines
- Any other motorized equipment

Besides these appliances, the greatest threats to a system's power supply are surges or blackouts that are caused by electrical storms. Whenever possible, turn off the system and peripherals, if any, and unplug them from their power sources during thunderstorms. If a blackout occurs—even a temporary one—while the system is turned on, turn off the system immediately and disconnect it from the electrical outlet. Leaving the system on may cause problems when the power is restored; all other appliances left on in the area may create large voltage spikes that may damage the system.

System Grounding



Warning When installing or replacing the unit, the ground connection must always be made first and disconnected last. **Statement 1046**



Warning Use copper conductors only. **Statement 1025**

You must install a system ground as part of the chassis installation process. Chassis installations that rely only on the AC third-prong ground are insufficient to adequately ground the systems.

Proper grounding practices ensure that the buildings and the installed equipment within them have low-impedance connections and low-voltage differentials between chassis. When you install a system ground, you reduce or prevent shock hazards, chances of equipment damage due to transients, and the potential for data corruption.

Without proper and complete system grounding, you run the risk of increased component damage due to ESD. Additionally, you have a greatly increased chance of data corruption, system lockup, and frequent system reboot situations by not using a system ground.



Caution Installations that rely solely on system grounding that uses only an AC third-prong ground run a substantially greater risk of equipment problems and data corruption than those installations that use both the AC third-prong ground and a properly installed system ground.

The following table lists some general grounding practice guidelines.

Table 8: Grounding Practice Guidelines

Environment	Electromagnetic Noise Severity Level	Grounding Recommendations
<p>Commercial building is subjected to direct lightning strikes.</p> <p>For example, some places in the United States, such as Florida, are prone to more lightning strikes than other areas.</p>	High	<p>All lightning protection devices must be installed in strict accordance with manufacturer recommendations.</p> <p>Conductors carrying lightning current should be spaced away from power and data lines in accordance with applicable recommendations and building codes. Best grounding practices must be closely followed.</p>
<p>Commercial building is located in an area where lightning storms occur frequently, but is not prone to direct lightning strikes.</p>	High	<p>Best grounding practices must be closely followed.</p>
<p>Commercial building contains a mix of information technology equipment and industrial equipment, such as welding.</p>	Medium to High	<p>Best grounding practices must be closely followed.</p>
<p>Existing commercial building is not subject to natural environmental noise or man-made industrial noise. This building contains a standard office environment. This installation has a history of malfunction due to electromagnetic noise.</p>	Medium	<p>Best grounding practices must be closely followed. Determine source and cause of noise if possible, and mitigate as closely as possible at the noise source or reduce coupling from the noise source to the victim equipment.</p>
<p>New commercial building is not subject to natural environmental noise or man-made industrial noise. This building contains a standard office environment.</p>	Low	<p>Best grounding practices should be followed as closely as possible. Electromagnetic noise problems are not anticipated, but installing a best-practice grounding system in a new building is often the least expensive route, and the best way to plan for the future.</p>
<p>Existing commercial building is not subject to natural environmental noise or man-made industrial noise. This building contains a standard office environment.</p>	Low	<p>Best grounding practices should be followed as much as possible. Electromagnetic noise problems are not anticipated, but installing a best-practice grounding system is always recommended.</p>



Note In all situations, grounding practices must comply with Section 250 of the National Electric Code (NEC) requirements or local laws and regulations. A 6 AWG grounding wire is preferred from the chassis to the rack ground or directly to the common bonding network (CBN). The equipment rack should also be connected to the CBN with a 6 AWG grounding wire.



Note Grounding lugs must be installed on the location marked on the chassis only.



Note Always ensure that all of the modules are completely installed and that the captive installation screws are fully tightened. In addition, ensure that all the I/O cables and power cords are properly seated. These practices are normal installation practices and must be followed in all installations.

Maintaining Safety with Electricity

When working on electrical equipment, follow these guidelines:

- Do not work alone if potentially hazardous conditions exist anywhere in your work space.
- Never assume that power is disconnected from a circuit; always check the circuit before working on it.
- When the power is switched off, put a lock-box on the circuit, so that no one can accidentally switch it on.
- Look carefully for possible hazards in your work area, such as damp floors, ungrounded power extension cables, frayed or damaged power cords, and missing safety grounds.
- If an electrical accident occurs, proceed as follows:
 - Use extreme caution; do not become a victim yourself.
 - Disconnect power from the system.
 - Seek medical attention, if necessary.
- Use the product within its marked electrical ratings and product usage instructions.
- Install the product in compliance with local and national electrical codes.
- If any of the following conditions occur, contact the Cisco Technical Assistance Center:
 - The power cable or plug is damaged.
 - An object has fallen into the product.
 - The product has been exposed to water or other liquids.
 - The product has been dropped or shows signs of damage.
 - The product does not operate correctly when you follow the operating instructions.

- Use the correct external power source. Operate the product only from the type of power source indicated on the electrical ratings label. If you are not sure of the type of power source required, consult a local electrician.
- To help prevent electrical shock, plug all the power cables into properly grounded electrical outlets. These power cables are equipped with three-prong plugs to ensure proper grounding. Do not use adapter plugs or remove the grounding prong from a power cable.
- Observe power strip ratings. Make sure that the total current rating of all products that are plugged into the power strip does not exceed 80 percent of the power strip rating.
- Do not modify power cables or plugs yourself. Consult with a licensed electrician or your power company for site modifications. Always follow your local and national wiring codes.

Preventing ESD Damage

ESD damage might occur when modules or other FRUs are improperly handled, resulting in intermittent or complete failure of the modules or FRUs. Modules consist of printed circuit boards that are fixed in metal carriers. EMI shielding and connectors are integral components of a carrier. Although the metal carrier helps to protect the board from ESD, always use an ESD-grounding strap when handling modules. To prevent ESD damage, follow these guidelines:

- Always use an ESD wrist or ankle strap and ensure that it makes good skin contact.
- Connect the equipment end of the strap to an unfinished chassis surface.
- When installing a component, use an available ejector lever to properly seat the bus connectors in the backplane or midplane. These devices prevent accidental removal, provide proper grounding for the system, and help to ensure that bus connectors are properly seated.
- When removing a component, use an available ejector lever to release the bus connectors from the backplane or midplane.
- Handle carriers by available handles or edges only; avoid touching the printed circuit boards or connectors.
- Place a removed component board-side-up on an antistatic surface or in a static-shielding container. If you plan to return the component to the factory, immediately place it in a static-shielding container.
- Avoid contact between the printed circuit boards and clothing. The wrist strap only protects components from ESD voltages on the body; ESD voltages on clothing can still cause damage.
- Never attempt to remove the printed circuit board from the metal carrier.

Tools and Equipment

Obtain these necessary tools:

- A Number-2 Phillips screwdriver.

Verifying Switch Operation

Before you install the switch in a rack or on a table or shelf, power on the switch and verify that it passes POST.

To power on the switch, plug one end of the AC power cord into the switch AC power connector, and plug the other end into an AC power outlet.

As the switch powers on, it begins the POST, a series of tests that runs automatically to ensure that the switch functions properly. LEDs can blink during the test. POST lasts approximately 1 minute. The SYST LED blinks green, and the other LEDs remain solid green.

When the switch completes POST successfully, the SYST LED remains green. The LEDs turn off and then reflect the switch operating status. If a switch fails POST, the SYST LED turns amber.

POST failures are usually fatal. Call Cisco technical support representative if your switch fails POST.

After a successful POST, unplug the power cord from the switch and install the switch in a rack, on a table, or on a shelf.



CHAPTER 3

Installing the Switch

- [Shipping Box Contents](#), on page 29
- [Planning a Switch Data Stack](#), on page 30
- [Mounting the Switch](#), on page 36
- [Connecting to the StackWise Ports](#), on page 41
- [Connecting Devices to the Ethernet Ports](#), on page 43

Shipping Box Contents

The shipping box contains the model of the switch you ordered and other components needed for installation. Some components are optional, depending on your order.



Note Verify that you have received these items. If any item is missing or damaged, contact your Cisco representative or reseller for instructions. Verify that you have received these items. If any item is missing or damaged, contact your Cisco representative or reseller for instructions.

Figure 8: Components delivered in the shipping box

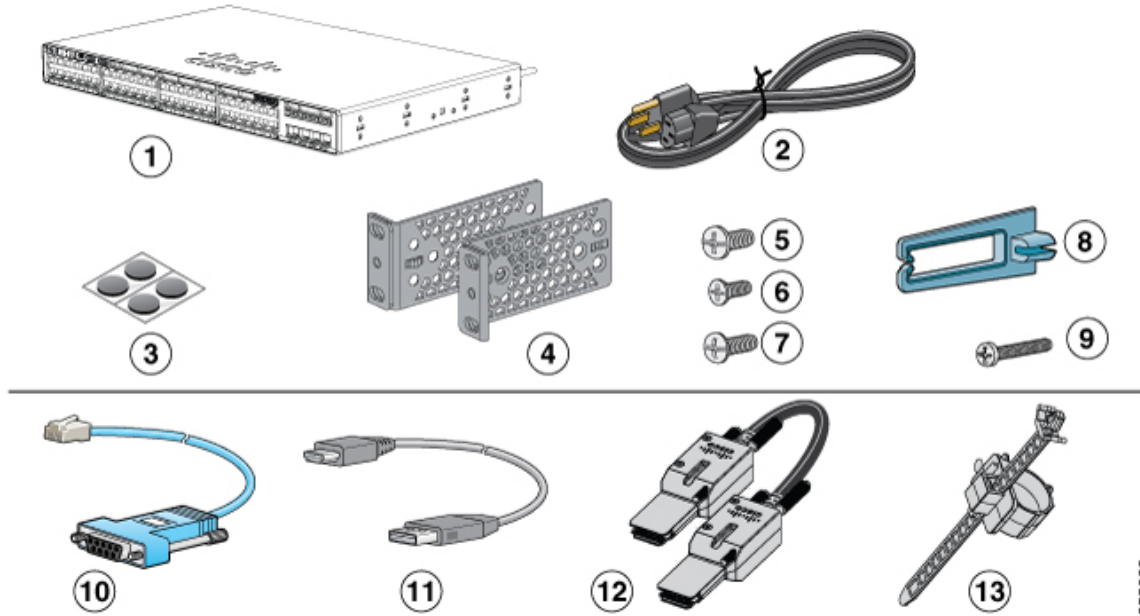

1	Cisco Catalyst 9200 Series switch ¹ (power supply modules are not displayed)	8	Cable guide
2	AC power cord	9	M4.0 x 20mm Phillips pan-head screw
3	Four rubber mounting feet	10	RJ-45 USB console cable ¹
4	Two 19-inch mounting brackets	11	(Optional) USB console cable ¹
5	4 number-12 pan-head screw	12	(Optional) StackWise cable ¹ (0.5-meter, 1-meter, or 3-meter)
6	4 number-10 pan-head screws	13	Power cord retainer
7	8 number-8 Phillips flat-head screws	-	-

1. Item is orderable.

Planning a Switch Data Stack

Switch Stacking Guidelines

A StackWise adapter must be installed in the stacking port to enable stacking. The StackWise cable connects to the StackWise adapter in the stacking port. If the switch is not ordered with stacking, the adapters must be ordered separately and installed.

Before connecting the switches in a stack, observe these stacking guidelines:

- Number of switches in the stack. You can create data stacks with up to eight switches in a stack.
- Length of the cable. Order the appropriate cable from your Cisco sales representative. The length of the cable depends on your configuration. These are the different sizes available:
 - 0.5 meter cable (STACK-T4-50CM)
 - 1 meter cable (STACK-T4-1M)
 - 3 meter cable (STACK-T4-3M)
- Minimum bend radius and coiled diameter for StackWise cables. We recommend a minimum bend radius and coiled diameter for each StackWise cable.

Table 9: StackWise Cables Minimum Bend Radius and Coiled Diameter

Cable Part Number	Cable Length	Minimum Bend Radius	Minimum Coiled Diameter
STACK-T4-50CM	1.64 feet (0.5 m)	2.60 in. (66 mm)	5.20 in. (132 mm)
STACK-T4-1M	3.28 feet (1.0 m)	2.60 in. (66 mm)	5.20 in. (132 mm)
STACK-T4-3M	9.84 feet (3.0 m)	3.58 in. (91 mm)	7.17 in. (182 mm)

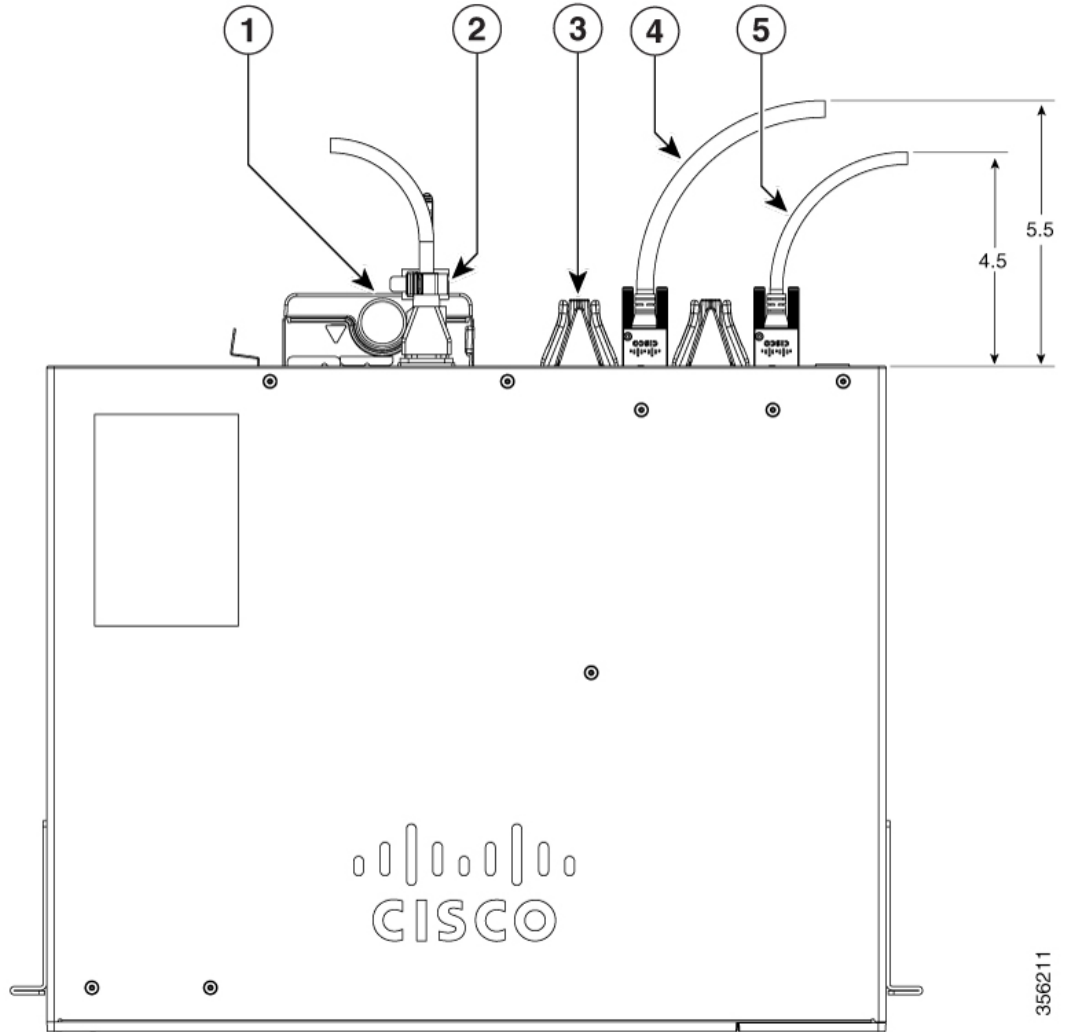

356211

1	Power supply module	4	StackWise 3.0 m cable
2	Power cord retainer	5	StackWise 1.0 m and 0.5 m cable
3	Fan module	-	



Note Ensure that you maintain a proper clearance of 5.5 in. and 4.5 in. between the StackWise cable and the switch as depicted in the image.

Data Stack Cabling Configurations

This is an example of a recommended configuration that uses the supplied 0.5-meter StackWise cable. In this example, the switches are stacked in a vertical rack or on a table. This configuration provides redundant

connections. The configuration example uses the supplied 0.5-meter StackWise cable. The example shows the full-ring configuration that provides redundant connections.

Figure 9: Data Stacking the Switches in a Rack or on a Table Using the 0.5-meter StackWise Cables

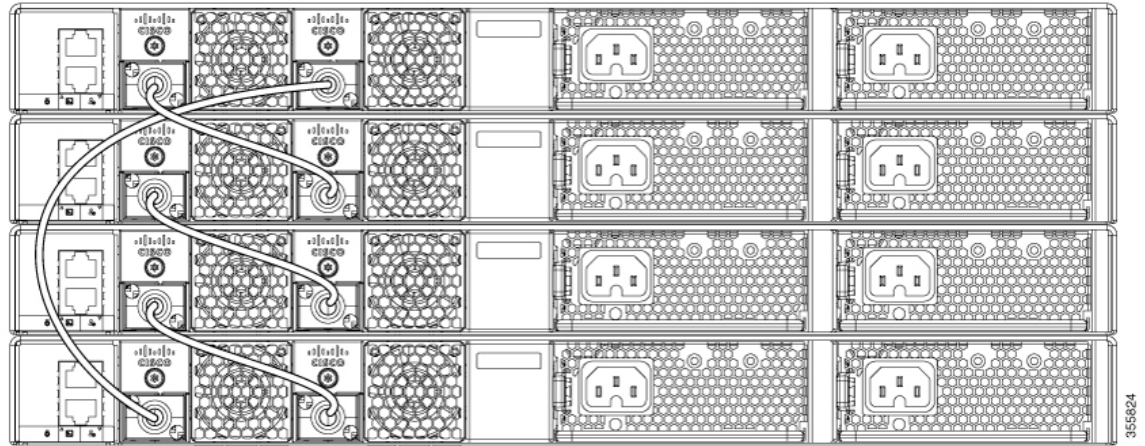

This example shows a recommended configuration when the switches are mounted side-by-side. Use the 1-meter and the 3-meter StackWise cables to connect the switches. This configuration provides redundant connections.

Figure 10: Data Stacking in a Side-by-Side Mounting



Data Stack Bandwidth and Partitioning Examples

This section provides examples of data stack bandwidth and possible data stack partitioning. The figure shows a data stack of switches that provides full bandwidth and redundant StackWise cable connections.

Figure 11: Example of a Data Stack with Full Bandwidth Connections

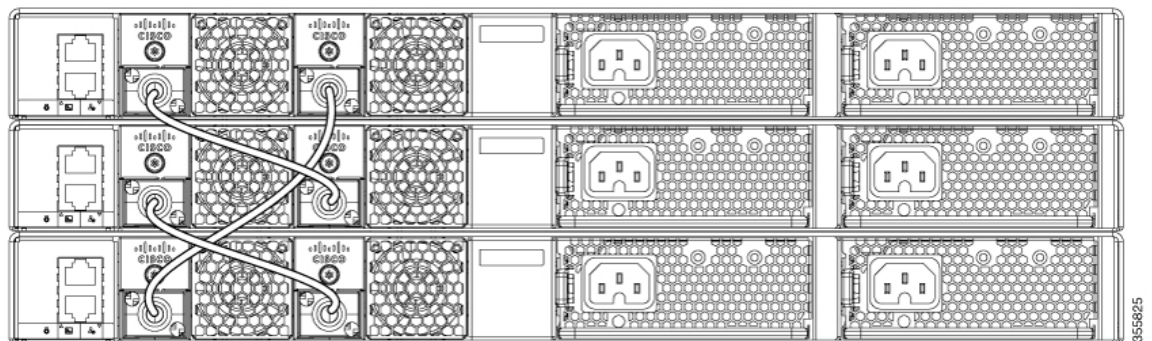

This figure shows an example of a stack of switches with incomplete StackWise cabling connections. This stack provides only half bandwidth and does not have redundant connections.

Figure 12: Example of a Data Stack with Half Bandwidth Connections

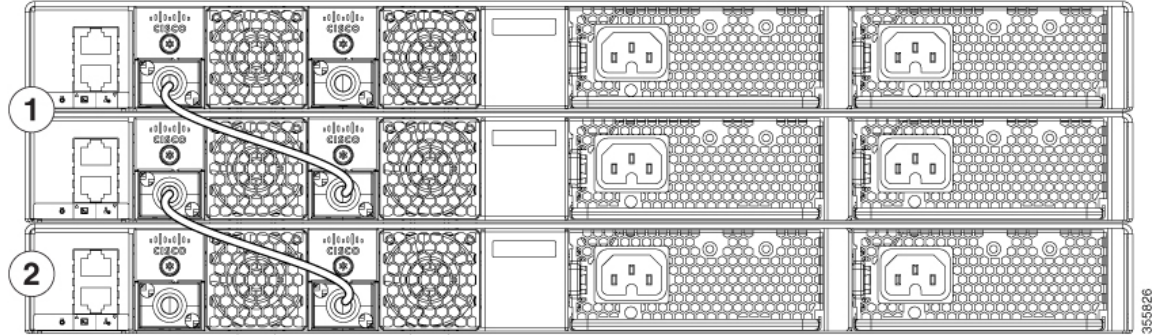

The figures below show data stacks of switches with failover conditions. In this figure, the StackWise cable is bad in link 2. Therefore, this stack provides only half bandwidth and does not have redundant connections.

Figure 13: Example of a Data Stack with a Failover Condition

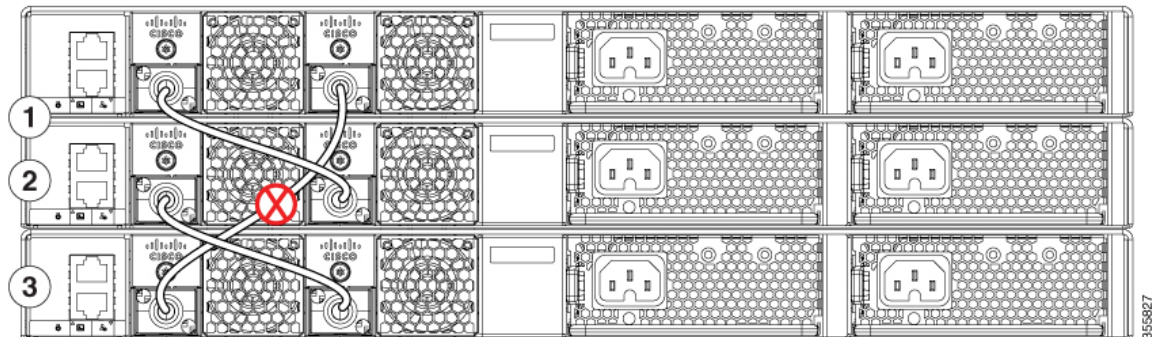

In this figure, link 2 is bad. Therefore, this stack partitions into two stacks, and the top and bottom switches become the active switch in the stack. If the bottom switch is a member (not active or standby switch), it reloads.

Figure 14: Example of a Partitioned Data Stack with a Failover Condition

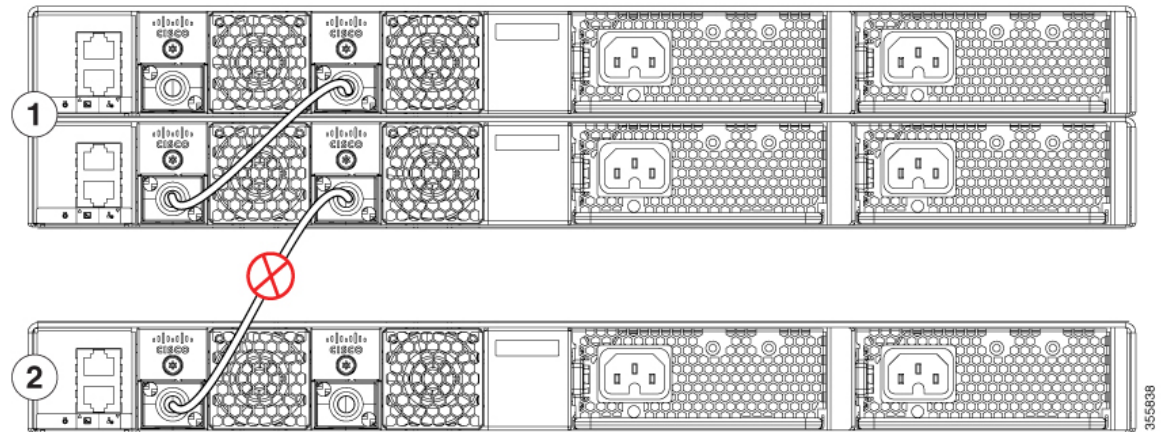

Power-On Sequence for Switch Stacks

Consider these guidelines before you power on the switches in a stack:

- The sequence in which the switches are first powered on might affect the switch that becomes the stack master.
- There are two ways to elect an active switch:
 - If you want a particular switch to become the active switch, configure it with the highest priority. Among switches with same priority, the switch with the lowest MAC address becomes the active switch.
 - If you want a particular switch to become the active switch, power on that switch first. This switch remains the active switch until a reelection is required. After 2 minutes, power on the other switches in the stack. If you have no preference as to which switch becomes the active switch, power on all the switches in the stack within 1 minute. These switches participate in the active switch election. Switches powered on after 2 minutes do not participate in the election.
- Power off a switch before you add it to or remove it from an existing switch stack. If changes are made to the stack without powering down the switches, the following results can occur:
 - If two operating partial ring stacks are connected together using a stack cable, a stack merge can take place. This situation reloads the whole stack (all switches in the stack).
 - If some switches in the stack are completely separated from the stack, a stack split can occur.
- A stack split can occur on a full ring stack if:
 - More than one running switch is removed without powering down.
 - More than one stack cable is removed without powering down.
- A stack split can occur in a partial ring stack if:
 - A switch is removed without powering down.

- A stack cable is removed without powering down.
- In a split stack, depending on where the active and standby switches are located, either two stacks might be formed (with the standby taking over as the new active switch in the newly formed stack) or all the members in the newly formed stack might reload.



Note These results depend on how the switches are connected. You can remove two or more switches from the stack without splitting the stack.

For conditions that can cause a stack reelection or to manually elect the active switch, see the stacking software configuration guide *Stack Manager and High Availability Configuration Guide for Cisco Catalyst 9200 Series Switches* on Cisco.com.

Mounting the Switch

The following sections explain the different mounting options.

Rack-Mounting

Installation in racks other than 19-inch racks requires a bracket kit not included with the switch.



Warning To prevent bodily injury when mounting or servicing this unit in a rack, you must take special precautions to ensure that the system remains stable. The following guidelines are provided to ensure your safety:

- This unit should be mounted at the bottom of the rack if it is the only unit in the rack.
- When mounting this unit in a partially filled rack, load the rack from the bottom to the top with the heaviest component at the bottom of the rack.
- If the rack is provided with stabilizing devices, install the stabilizers before mounting or servicing the unit in the rack.

Statement 1006

Figure 15: Rack-Mounting Brackets

This figure shows the standard 19-inch brackets and other optional mounting brackets. You can order the optional brackets (ACC-KIT-T1=) from your Cisco sales representative.

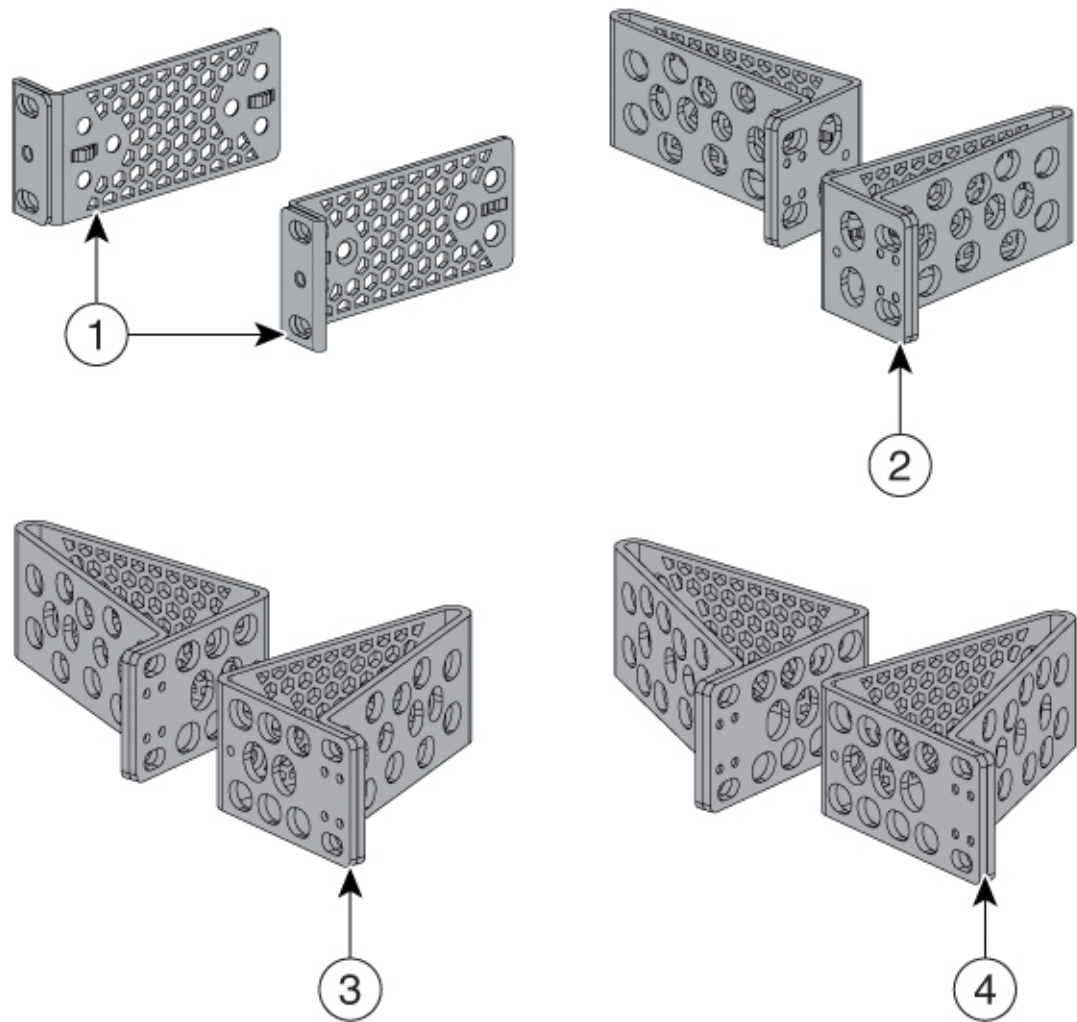

356067

1	19-inch brackets (ACC-KIT-T1=)	3	23-inch brackets (RACK-KIT-T1=)
2	ETSI brackets (RACK-KIT-T1=)	4	24-inch brackets (RACK-KIT-T1=)

Attaching the Rack-Mount Brackets

Before you begin

You can use the minimum recommended number of two screws for installing the rack-mount bracket to each side of the switch. If required, while mounting, you can use the additional four screws provided in the accessory kit.

Procedure

Use two Phillips flat-head screws to attach the long side of the bracket to each side of the switch for the front- or rear-mounting positions.

The following illustration shows a C9200L switch. C9200 switches follow the same method for installing the rack mount bracket.

Figure 16: Attaching Brackets for 19-inch Racks in a two-post rack front-mount position

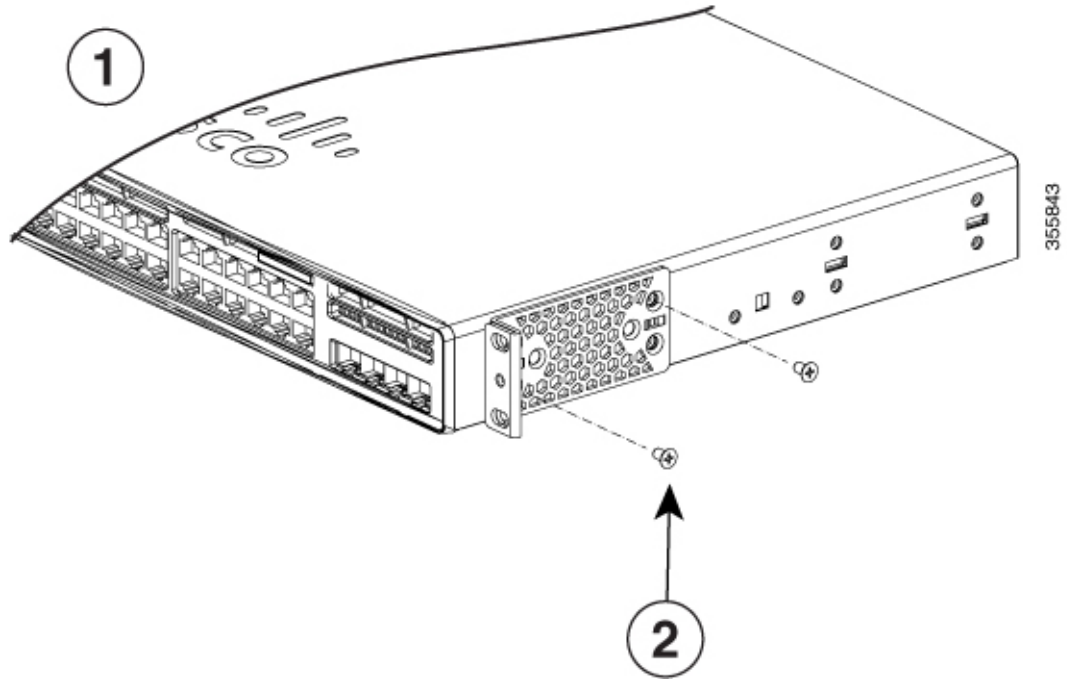
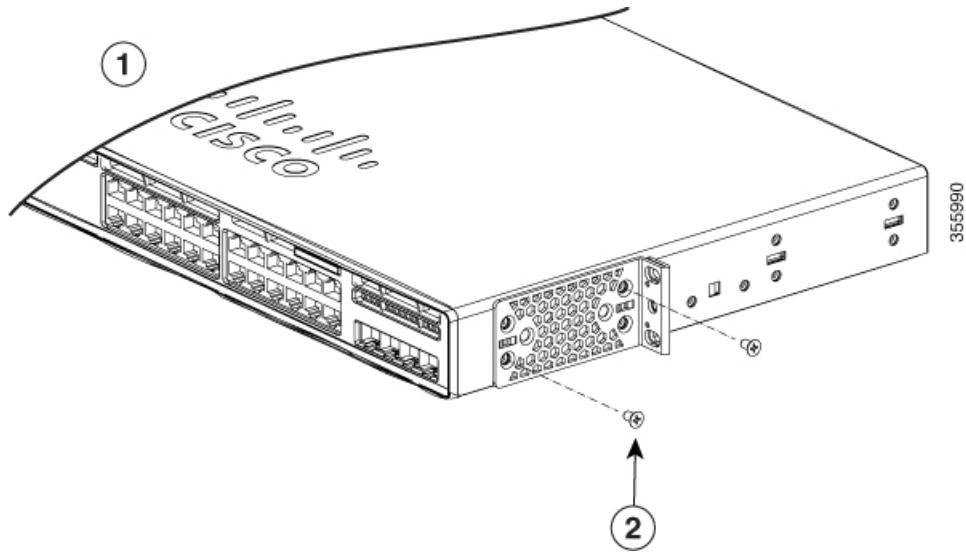

Figure 17: Attaching Brackets for 19-inch Racks in a two-post rack rear-mount position



2	Number-8 Phillips flat-head screws
---	------------------------------------

Mounting the Switch in a Rack

Procedure

- Step 1** Use the four supplied Phillips machine screws to attach the brackets to the rack.
- Step 2** Use the black Phillips machine screw to attach the cable guide to the left or right bracket.

Figure 18: Mounting the Switch in a Rack

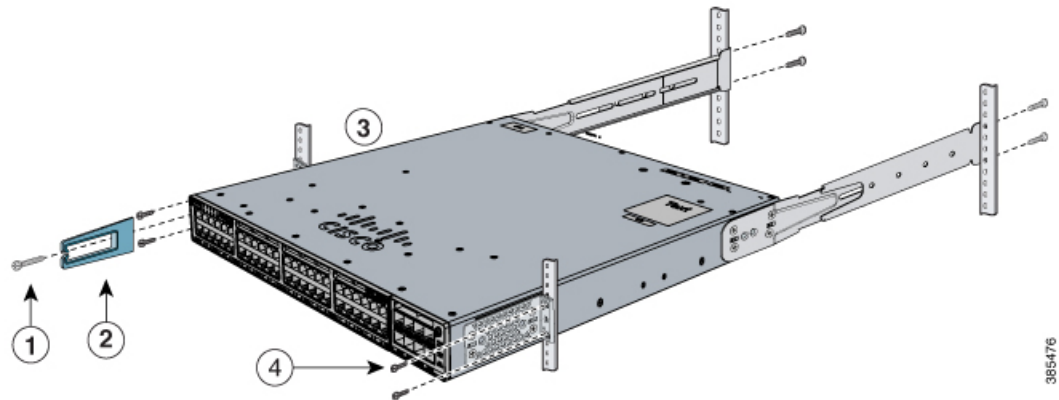

1	Phillips machine screw, black	3	Front-mounting position
2	Cable guide	4	Number-12 or number-10 Phillips machine screws

Installing the Switch on a Table or Shelf

Procedure

- Step 1** To install the switch on a table or shelf, locate the adhesive strip with the rubber feet in the mounting-kit envelope.
- Step 2** Attach the four rubber feet to the four circular etches on the bottom of the chassis.

Figure 19: Attaching the mounting feet for Table-Mounting or Shelf-Mounting

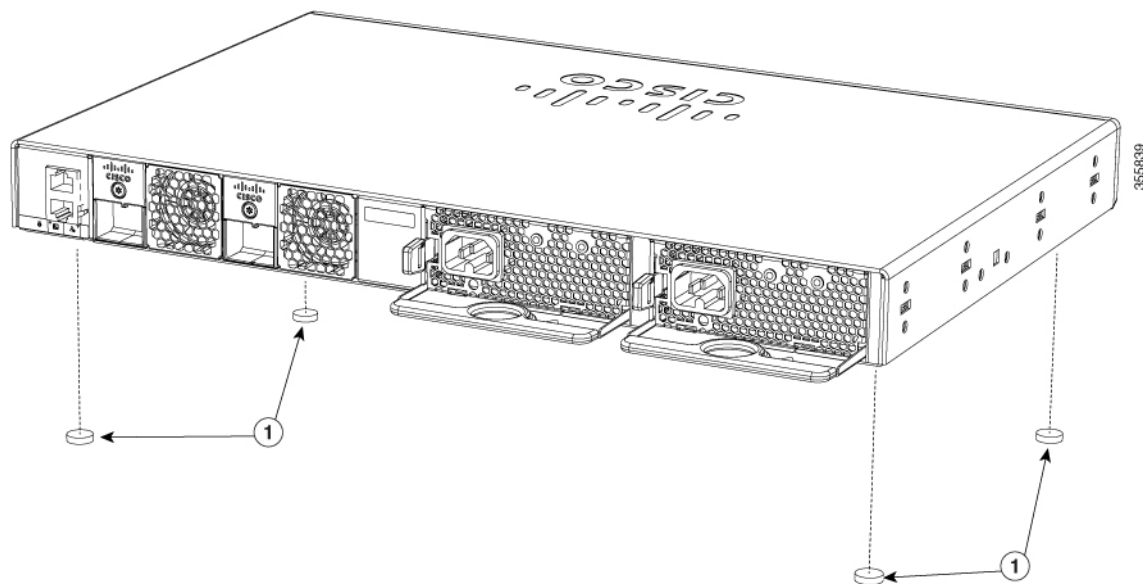

1	Rubber mounting feet
---	----------------------

Step 3 Place the switch on the table or shelf near an AC power source.

What to do next

When you complete the switch installation, see [After Switch Installation, on page 40](#) for information on switch configuration.

After Switch Installation

- Configure the switch using the Web User Interface. For more information, see "Configuring the Switch Using the Web User Interface" topic in the *Software Configuration Guide*.
- Connect the required devices to the switch ports.
- Turn on the power supply switches to power up the system. While powering up, the switch performs a series of bootup diagnostic tests.



Note The switch is designed to boot up in less than 30 minutes, provided that the neighboring devices are in fully operational state.

- Verify port connectivity after connecting devices to the switch ports. The LED turns green when the switch and the attached device have a link.

Connecting to the StackWise Ports

Before you begin

Before connecting the StackWise cables, read the "Planning a Switch Data Stack" section. Always use a Cisco-approved StackWise cable to connect the switches.

Procedure

- Step 1** Remove the dust covers from the StackWise cables and StackWise ports, and store them for future use.
- A StackWise adapter must be installed in the StackWise port to enable stacking. In the default setup, the StackWise adapter blanks are installed in the StackWise ports. If StackWise stacking is ordered with the switch, StackWise adapters are already installed in the StackWise ports, and you can proceed to step 4.
- Step 2** Remove the StackWise adapter blanks from each destination StackWise port using the Torx T15 Allen key provided in the stacking kit (or a Torx T15 screwdriver). Store them for future use.
- Step 3** Install a StackWise adapter in each destination StackWise port, and secure it in place using the supplied Torx T15 key, or a Torx T15 screwdriver.

Figure 20: Installing the StackWise Adapter in a StackWise Port

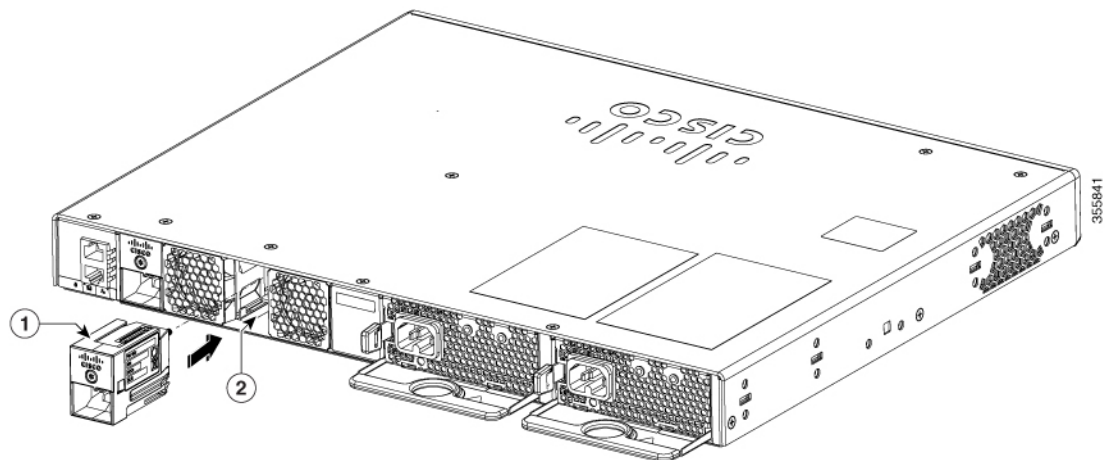

1 StackWise adapter

2 StackWise port

- Step 4** Connect the cable to the StackWise port on the switch rear panel.
- Align the StackWise cable connector with the StackWise adapter in the StackWise port.
 - Insert the StackWise cable connector into the StackWise port. Make sure that the Cisco logo is on the top side of the connector.

Figure 21: Connecting the StackWise Cable in a StackWise Port

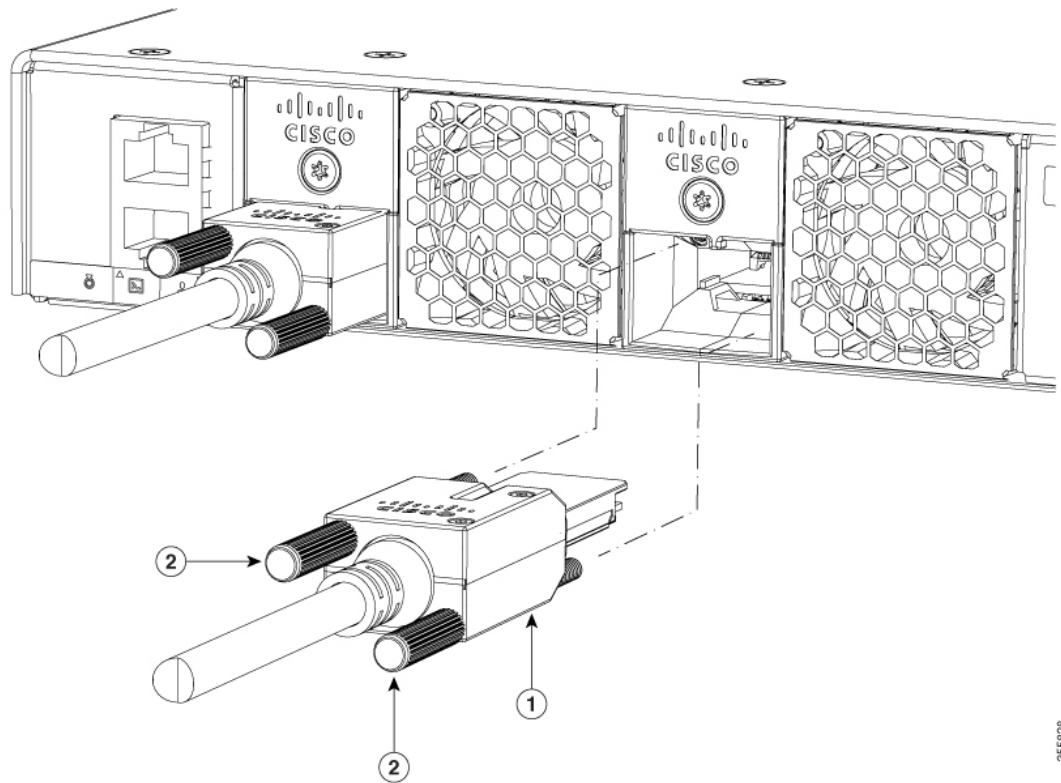

1 Connector screws

2 StackWise cable

c) Finger-tighten the screws in clockwise direction.

Step 5

Connect the other end of the cable to the port on the other switch and finger-tighten the screws. Avoid over-tightening the screws.

Caution Removing and installing the StackWise cable can shorten its useful life. Do not remove and insert the cable more often than is absolutely necessary (installing and removing it up to 200 times is supported).

When you need to remove the StackWise cable from the connector, make sure to fully unscrew the correct screws. When the connectors are not being used, replace the dust covers.

Connecting Devices to the Ethernet Ports

10/100/1000/Multigigabit Ethernet Port Connections

The switch 10/100/1000 and Multigigabit Ethernet port configuration changes to operate at the speed of the attached device. If the attached ports do not support autonegotiation, you can manually set the speed and duplex parameters. Connecting devices that do not autonegotiate or that have the speed and duplex parameters manually set can reduce performance or result in no linkage.

To maximize performance, choose one of these methods for configuring the Ethernet ports:

- Let the ports autonegotiate both speed and duplex.
- Set the interface speed and duplex parameters on both ends of the connection.

Auto-MDIX Connections

The autonegotiation and the auto-MDIX features are enabled by default on the switch.

With autonegotiation, the switch port configurations change to operate at the speed of the attached device. If the attached device does not support autonegotiation, you can manually set the switch interface speed and duplex parameters.

With auto-MDIX, the switch detects the required cable type for copper Ethernet connections and configures the interface accordingly.

If auto-MDIX is disabled, use the guidelines in this table to select the correct cable.

Table 10: Recommended Ethernet Cables (When Auto-MDIX is Disabled)

Device	Crossover Cable	Straight-Through Cable
Switch to switch	Yes	No
Switch to hub	Yes	No
Switch to computer or server	No	Yes
Switch to router	No	Yes
Switch to IP phone	No	Yes

¹ 100BASE-TX and 1000BASE-T traffic requires twisted four-pair, Category 5 or higher. 10BASE-T traffic can use Category 3 cable or higher.

PoE and POE+ Port Connections

The 10/100/1000 PoE and PoE+ ports have the same autonegotiation settings and cabling requirements that are described in the [10/100/1000 Ports, on page 4](#). These ports can provide PoE and PoE+ inline power.

PoE inline power supports devices compliant with the IEEE 802.3af standard, as well as prestandard Cisco IP Phones and Cisco Aironet Access Points. Each port can deliver up to 15.4 W of PoE. PoE+ inline power supports devices compliant with the IEEE 802.3at standard, by delivering up to 30 W of PoE+ power per port to all switch ports.

See [Power Supply Modules, on page 11](#) for the power supply modules required to support PoE and PoE+ on 24- and 48-port switches.



Warning Voltages that present a shock hazard may exist on Power over Ethernet (PoE) circuits if interconnections are made using uninsulated exposed metal contacts, conductors, or terminals. Avoid using such interconnection methods, unless the exposed metal parts are located within a restricted access location and users and service people who are authorized within the restricted access location are made aware of the hazard. A restricted access area can be accessed only through the use of a special tool, lock and key or other means of security. Statement 1072



Warning Voice over IP (VoIP) service and the emergency calling service do not function if power fails or is disrupted. After power is restored, you might have to reset or reconfigure equipment to regain access to VoIP and the emergency calling service. In the USA, this emergency number is 911. You need to be aware of the emergency number in your country. Statement 371



Caution Category 5e and Category 6 cables can store high levels of static electricity. Always ground the cables to a suitable and safe earth ground before connecting them to the switch or other devices.



Caution Noncompliant cabling or powered devices can cause a PoE port fault. Use only standard-compliant cabling to connect Cisco prestandard IP Phones and wireless access points, IEEE 802.3af, or 802.3at (PoE+)-compliant devices. You must remove any cable or device that causes a PoE fault.



CHAPTER 4

Installing a Network Module

- [Installing a Network Module in the Switch, on page 45](#)
- [Removing a Network Module, on page 49](#)
- [Finding the Network Module Serial Number, on page 50](#)
- [Installing and Removing Pluggable Transceiver Modules, on page 51](#)

Installing a Network Module in the Switch

Safety Warnings

This section includes the installation cautions and warnings. Translations of the safety warnings are available in the *Regulatory Compliance and Safety Information for Cisco Catalyst 9200 Series Switches*.

Read this section before you install a network module.



Caution Proper ESD protection is required whenever you handle equipment. Installation and maintenance personnel should be properly grounded by grounding straps to eliminate the risk of ESD damage to the equipment. Equipment is subject to ESD damage whenever you remove it.



Warning Only trained and qualified personnel should be allowed to install, replace, or service this equipment. Statement 1030



Warning Do not reach into a vacant slot or chassis while you install or remove a module. Exposed circuitry could constitute an energy hazard. Statement 206

Installing a Network Module



Note The switch can operate without a network module, but a blank module (with no ports or SFP slots) is available and should be installed when uplink ports are not required.



Note The switch generates logs when you insert or remove a network module with SFP/SFP+ slots.

Use only supported network modules and Cisco pluggable transceivers. Each module has an internal serial EEPROM that is encoded with security information.

The network module is hot-swappable. If you remove a module, replace it with another network module or a blank module.



Note The switch complies with EMC, safety, and thermal specifications when a network module is present. If no uplink ports are required, install a blank network module.

Before you begin

When installing network modules, observe these precautions:

- Do not remove the blank module from the slot unless you are installing a network module. A module must be in the uplink slot at all times.
- Do not remove the dust plugs from the pluggable transceivers or the rubber caps from the fiber-optic cable until you connect the cable. The plugs and caps protect the module ports and cables from contamination and ambient light.
- Removing and installing a network module can shorten its useful life. Do not remove and insert a network module more often than is necessary.
- To prevent ESD damage, follow your normal board and component handling procedures when connecting cables to the switch and other devices.

Procedure

Step 1 Attach an ESD-preventive wrist strap to your wrist and to an earth ground surface.

Step 2 Remove the module from the protective packaging.

Step 3 Remove the blank module from the switch and save it.

Figure 22: Removing the Blank Module

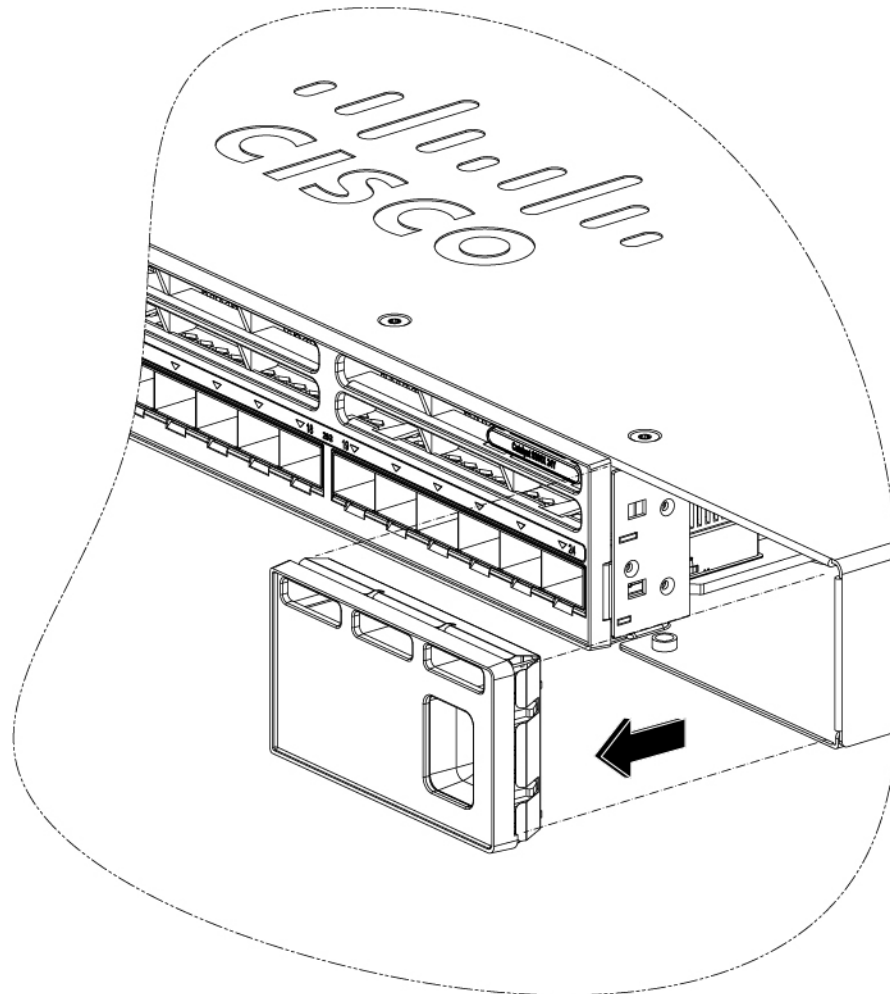

357395

Caution Verify the correct orientation of your module before installing it. Incorrect installation can damage the module.

Caution Do not install the network module with connected cables or installed pluggable transceivers. Always remove any cables and transceiver modules before you install the network module.

Caution A module interface might become error-disabled when a network module with connected fiber-optic cables is installed or removed. If an interface is error-disabled, you can reenable the interface by using the **shutdown** and **no shutdown** interface configuration commands.

Step 4 Position the module face up to install it in the module slot. Slide the module into the slot until the screw makes contact with the chassis. Fasten the captive screws to secure the network module in place.

Figure 23: Installing the Network Module in the Switch

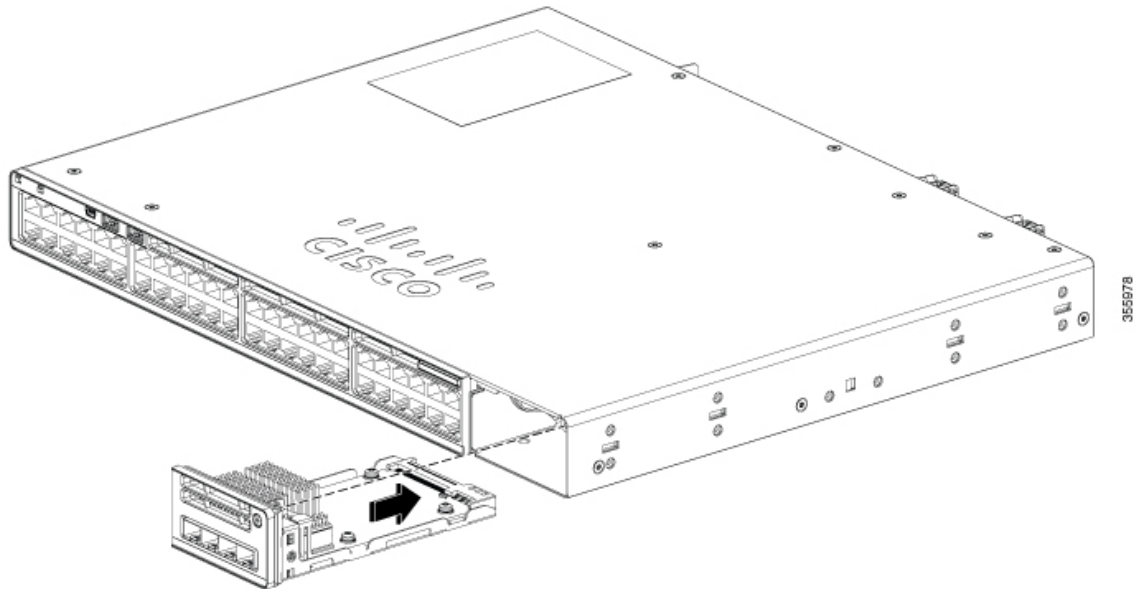

Step 5 Do one of the following:

- While installing C9300 network modules, position the module face up to install it in the module slot. Slide the module into the slot until the screw makes contact with the chassis. Fasten the captive screws to secure the network module in place.

Figure 24: Installing the C9300 Network Module in the Switch

- While installing C9300X network modules, position the module face up to install it in the module slot. Slide the module into the slot until the back of the module faceplate is flush with the switch faceplate. Secure the network module in place by the ejector and the latch.

Figure 25: Installing the C9300X Network Module in the Switch

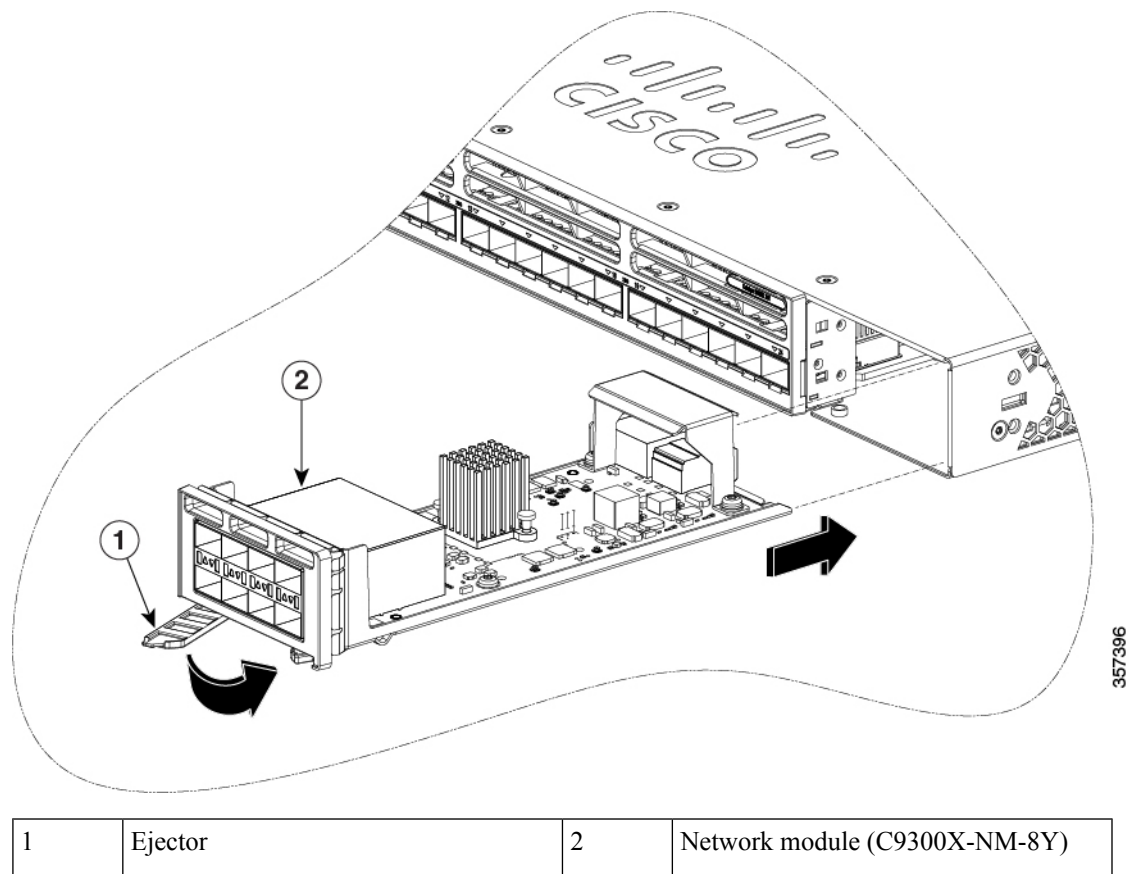

357396

Removing a Network Module



Note The switch complies with EMC, safety, and thermal specifications when a network module is present. If no uplink ports are required, install a blank network module.



Note To avoid authentication failure and non-detection of modules, wait for a minimum of 6-8 seconds between the online insertion and removal (OIR) of network modules.

Procedure

Step 1 Attach an ESD-preventive wrist strap to your wrist and to an earth ground surface

Caution Do not remove the network module with connected cables or installed pluggable transceiver modules. Always remove any cables and modules before you remove the network module.

Caution A module interface might become error-disabled when a network module with connected fiber-optic cables is installed or removed. If an interface is error-disabled, you can reenable the interface by using the **shutdown** and **no shutdown** interface configuration commands.

- Step 2** Disconnect the cables from the pluggable transceiver module.
 - Step 3** Remove the pluggable transceiver module from the network module.
 - Step 4** Loosen the captive screws that hold the network module in place until it completely disengages from the chassis.
 - Step 5** Carefully slide the network module out of the slot.
 - Step 6** Install a replacement network module or a blank module in the slot.
 - Step 7** Place the module that you removed in an antistatic bag or other protective environment.
-

Finding the Network Module Serial Number

If you contact Cisco Technical Assistance regarding a network module, you need to know its serial number.

Figure 26: Network Module Serial Number Location

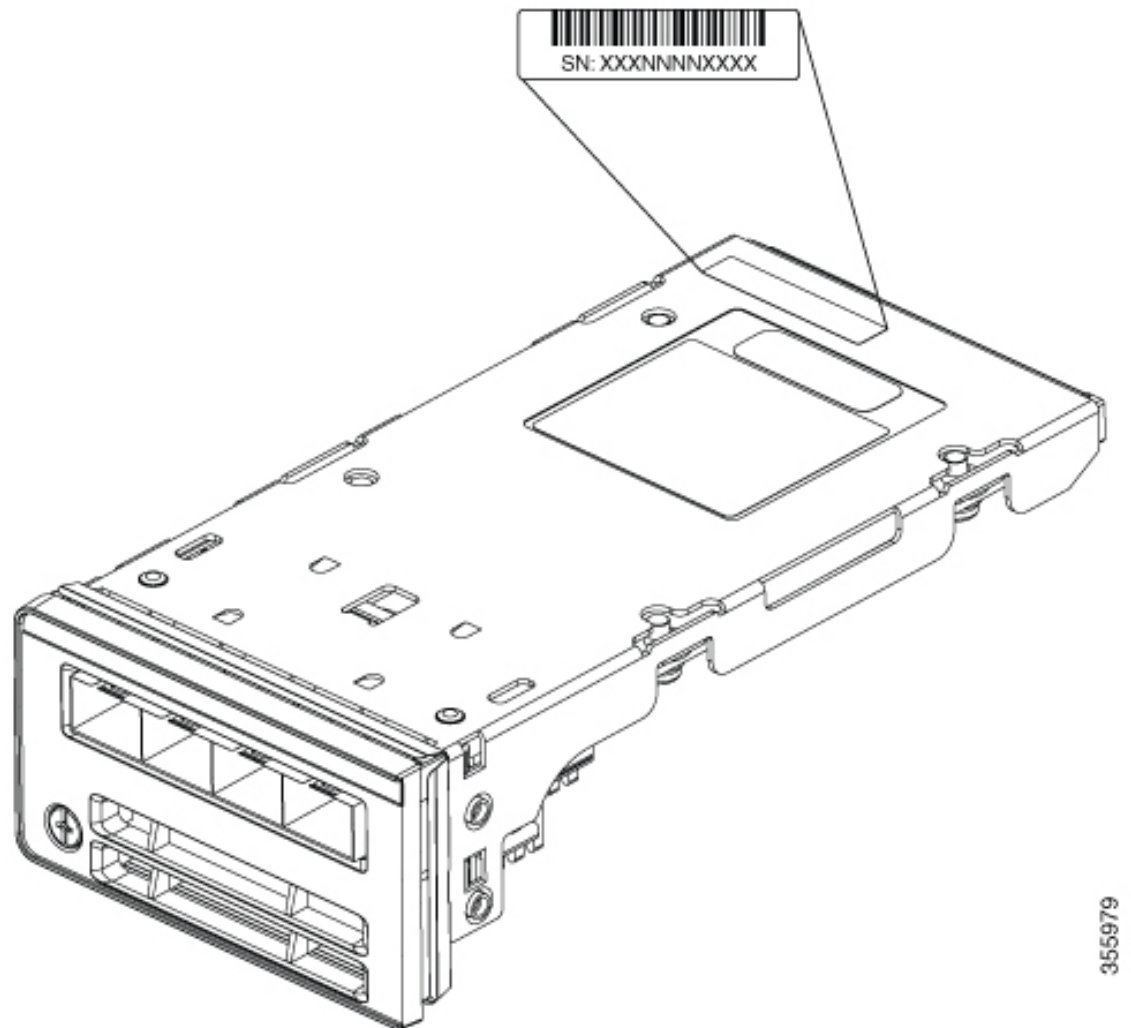

Installing and Removing Pluggable Transceiver Modules

Installing a Cisco Pluggable Transceiver Module

Before you begin

See the switch release notes on Cisco.com for the list of supported a Cisco pluggable transceiver modules (SFP, SFP, SFP28 and QSFP+ modules). Use only supported modules on the switch. For the latest information about the supported modules, refer to the [Cisco Transceiver Modules Compatibility Information](#).

For information about installing, removing, cabling, and troubleshooting transceiver modules, see the module documentation that shipped with your device.



Warning Class 1 laser product. Statement 1008

- Do not remove the dust plugs from the transceiver modules or the rubber caps from the fiber-optic cable until you are ready to connect the cable. The plugs and caps protect the module ports and cables from contamination and ambient light.
- Removing and installing a transceiver module can shorten its useful life. Do not remove and insert any module more often than necessary.
- To prevent ESD damage, follow your normal board and component handling procedures when connecting cables to the switch and other devices.
- When you insert several transceiver modules in multiple switch ports, wait for 5 seconds between inserting each transceiver module. This will prevent the ports from going into error disabled mode. Similarly, when you remove a transceiver module from a port, wait for 5 seconds before reinserting it.

Procedure

- Step 1** Attach an ESD-preventive wrist strap to your wrist and to an earth ground surface.
- Step 2** Find the send (TX) and receive (RX) markings that identify the top of the transceiver module. On some transceiver modules, the send and receive (TX and RX) markings might be shown by arrows that show the direction of the connection.
- Step 3** If the transceiver module has a bale-clasp latch, move it to the open, unlocked position.
- Step 4** Align the module in front of the slot opening, and push until you feel the connector snap into place.

Figure 27: Installing a Transceiver Module into the Network Module

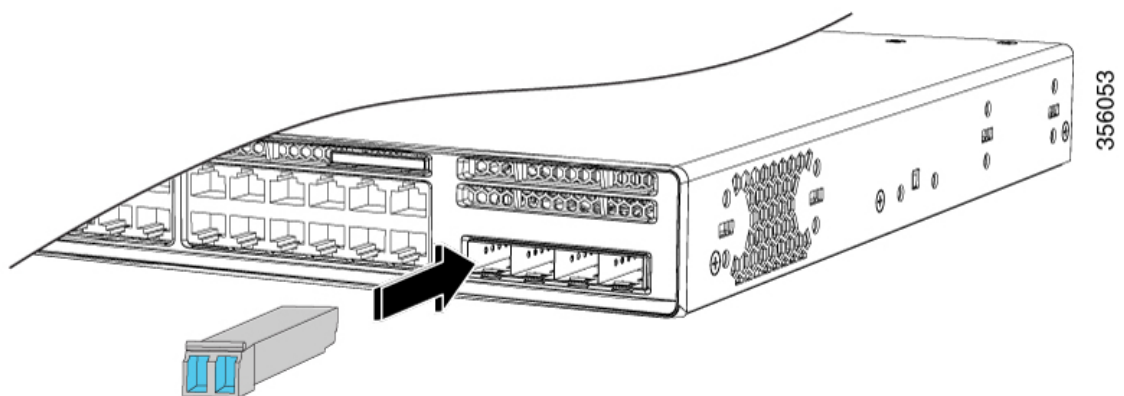

- Step 5** If the module has a bale-clasp latch, close it to lock the transceiver module in place.
- Step 6** Remove the transceiver module dust plugs and save.

- Step 7** Connect the transceiver module cables.

Figure 28: Installing a Transceiver Module in the Uplink Module Slot

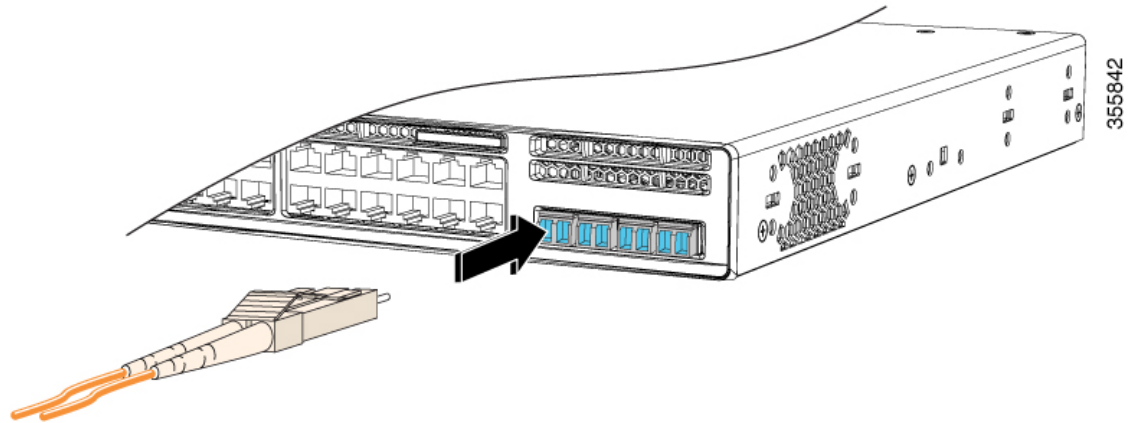

Removing a Cisco Pluggable Transceiver Module

Procedure

- Step 1** Attach an ESD-preventive wrist strap to your wrist and to an earth ground surface.
- Step 2** Disconnect the cable from the transceiver module. For reattachment, note which cable connector plug is send (TX) and which is receive (RX).
- Step 3** Insert a dust plug into the optical ports of the transceiver module to keep the optical interfaces clean.
- Step 4** If the module has a bale-clasp latch, pull the bale out and down to eject the module. If you cannot use your finger to open the latch, use a small, flat-blade screwdriver or other long, narrow instrument to open it.
- Step 5** Grasp the transceiver module and carefully remove it from the slot.
- Step 6** Place the transceiver module in an antistatic bag or other protective environment.



CHAPTER 5

Installing a Power Supply Unit

- [Power Supply Modules Overview](#), on page 55
- [Finding the Power Supply Module Serial Number](#), on page 58
- [Installation Guidelines](#), on page 59
- [Installing or Replacing an AC Power Supply Module](#), on page 60

Power Supply Modules Overview

The switch chassis has two power supply slots that operates with either one active power supply module and a redundant power supply module. You can use two AC modules or one AC module and a blank cover. The active and redundant modules must be of the same type.

All power supply modules have internal fans. All switches ship with a blank cover in the second power supply slot.

The main module is field replaceable and the redundant module is hot-swappable. The redundant power supply can also be used for extra PoE power.

Two power supply modules can be powered up from two different phases.

The following table describes the supported internal power supply modules.

Table 11: Power Supply Module Part Numbers and Descriptions

Part Number	Description
PWR-C5-125WAC	125 W AC power supply module
PWR-C5-600WAC	600 W AC power supply module
PWR-C5-1KWAC	1000 W AC power supply module
PWR-C6-125WAC ¹	125 W AC power supply module
PWR-C6-600WAC ¹	600 W AC power supply module
PWR-C6-1KWAC ¹	1000 W AC power supply module
PWR-C5-BLANK	Blank cover

1. Supported from Cisco IOS XE Gibraltar 16.11.1.

All the switches ship with a blank cover in the second power supply slot if the switches are ordered with only one power supply module.

For information about available PoE and PoE+ requirements, see these sections the [Power Supply Modules](#), on page 11.

The power supply modules are autoranging units that support input voltages between 100 and 240 VAC. Each AC power supply module has a power cord for connection to an AC power outlet. The modules use an 18-AWG power cord.

The following illustrations show the power supply modules.

Figure 29: 1000W AC Power Supply

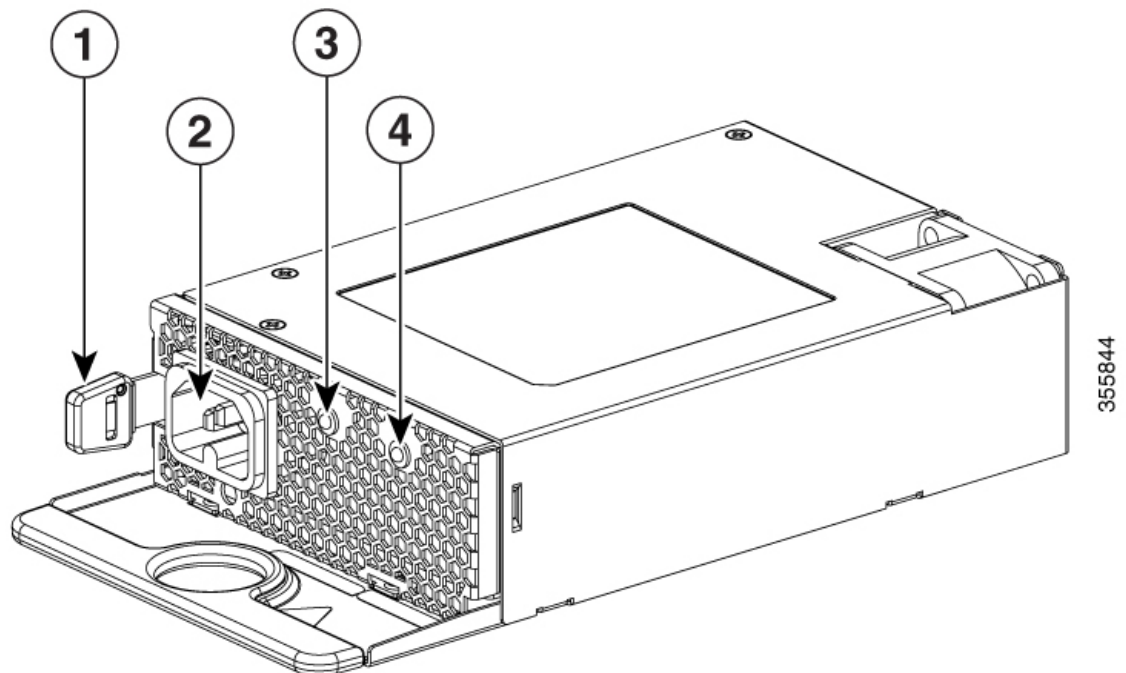
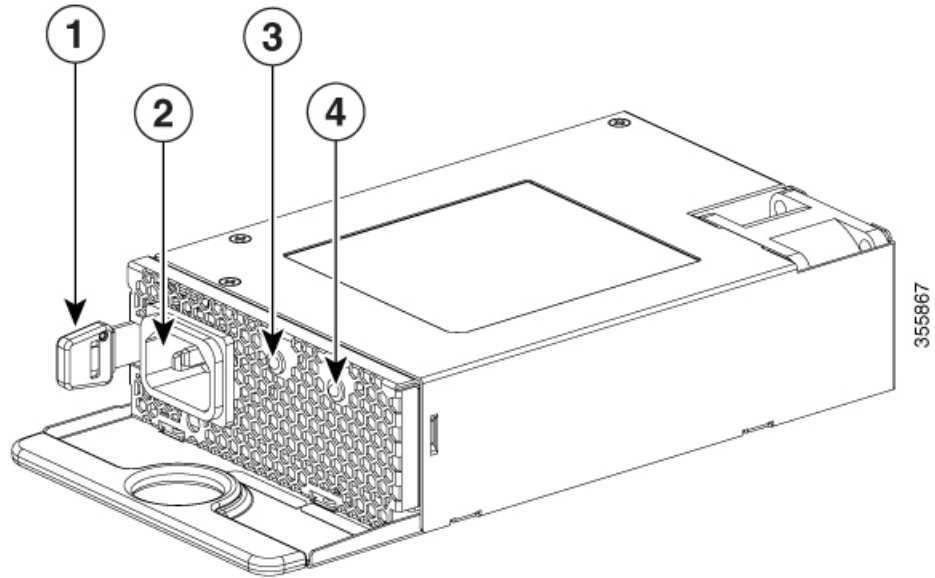

Figure 30: 125W AC Power Supply



1	Release latch	3	→] LED
2	AC power cord connector	4	←] LED

If no power supply is installed in a power supply slot, install a power supply slot cover.

Figure 31: Power Supply Slot Cover

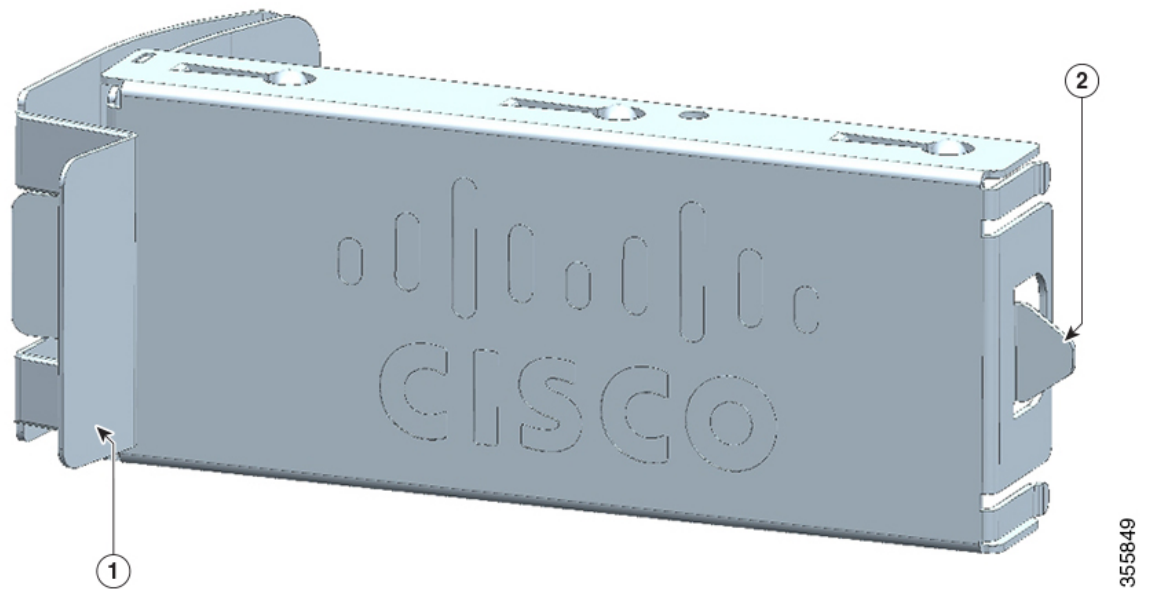

1	Release handles	2	Retainer clips
---	-----------------	---	----------------

Table 12: Switch Power Supply Module LEDs

→]	Description	←]	Description
Off	No AC input power.	Off	Output is disabled, or input is outside the operating range (LED is off).
Green	AC input power present.	Green	Power output to switch active.
		Red	Output has failed.

Finding the Power Supply Module Serial Number

If you contact Cisco Technical Assistance regarding a power supply module, you need to know the serial number. See the following illustrations to find the serial number. You can also use the CLI to find out the serial number.

Figure 32: AC Power Supply Serial Number

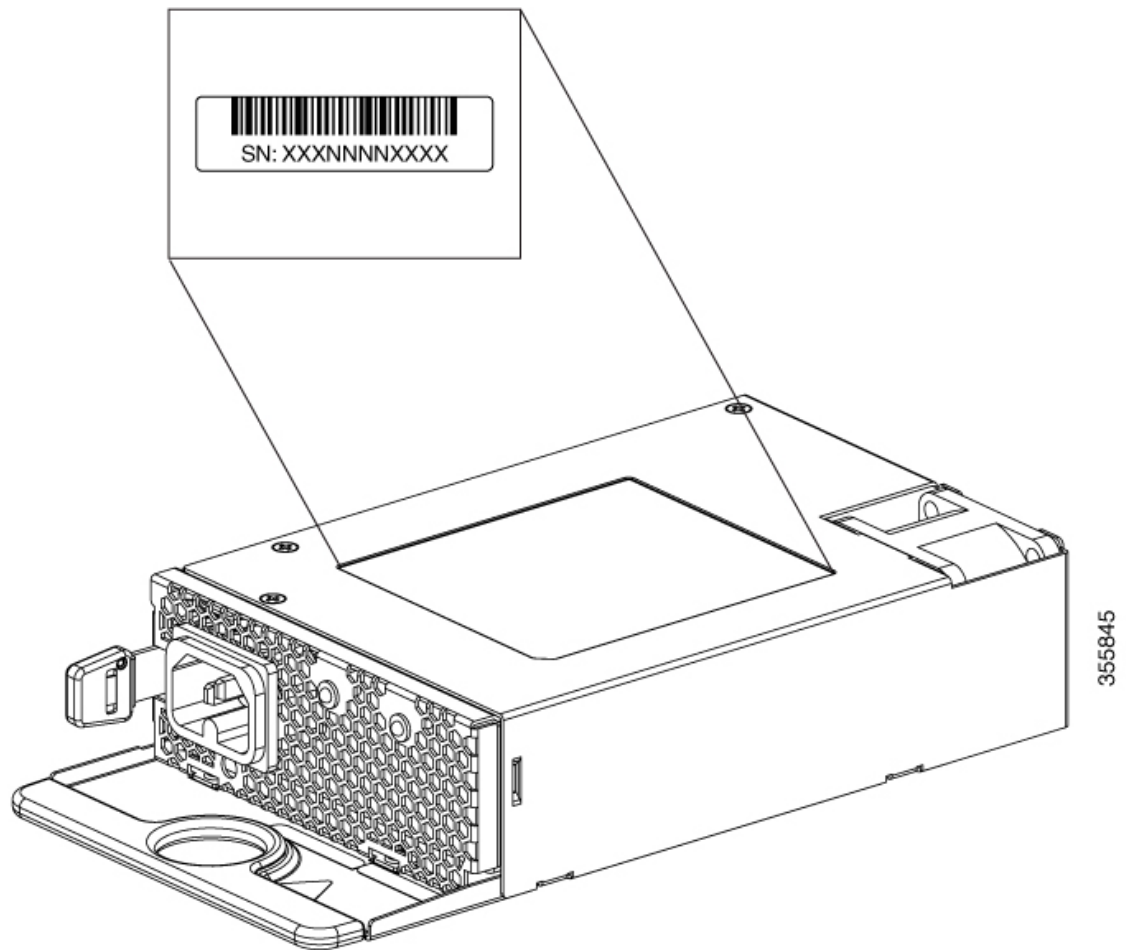

Installation Guidelines

Observe these guidelines when removing or installing a power supply module.

- Do not force the power supply module into the slot. This can damage the pins on the switch if they are not aligned with the module.
- A power supply module that is only partially connected to the switch can disrupt the system operation.
- Remove power from the power supply module before removing or installing the module.
- The power supply module is hot-swappable. In some configurations, such as full PoE+ or power sharing mode, removing a power supply module causes powered devices to shut down until the power budget matches the input power of a single power supply module. To minimize network interruption, ensure that an active backup is in progress.

For the switch commands that display available power budget, see the software configuration guide.



Caution Do not operate the switch with one power-supply module slot empty. For proper chassis cooling, both module slots must be populated, with either a power supply or a blank module.



Warning This equipment must be grounded. Never defeat the ground conductor or operate the equipment in the absence of a suitably installed ground conductor. Contact the appropriate electrical inspection authority or an electrician if you are uncertain that suitable grounding is available.

Statement 1024



Warning Blank faceplates and cover panels serve three important functions: they prevent exposure to hazardous voltages and currents inside the chassis; they contain electromagnetic interference (EMI) that might disrupt other equipment; and they direct the flow of cooling air through the chassis. Do not operate the system unless all cards, faceplates, front covers, and rear covers are in place.

Statement 1029



Warning Do not reach into a vacant slot or chassis while you install or remove a module. Exposed circuitry could constitute an energy hazard.

Statement 206



Warning Only trained and qualified personnel should be allowed to install, replace, or service this equipment.

Statement 1030



Warning If a Cisco external power system is not connected to the switch, install the provided connector cover on the back of the switch.

Statement 386

Installing or Replacing an AC Power Supply Module

Procedure

- Step 1** Turn off the power at its source.
- Step 2** Remove the power cord from the power cord retainer.
- Step 3** Remove the power cord from the power connector.

Step 4 Press the release latch at the right side of the power supply module inward and slide the power supply out.

Caution Do not leave the power-supply slot open for more than 90 seconds while the switch is operating.

Warning This unit might have more than one power supply connection. All connections must be removed to de-energize the unit. Statement 1028

Step 5 Insert the new power supply into the power-supply slot, and gently push it into the slot. When correctly inserted, the power supplies (excluding the power cord retainer) are flush with the switch rear panel.

Figure 33: Inserting the AC-Power Supply in the Switch

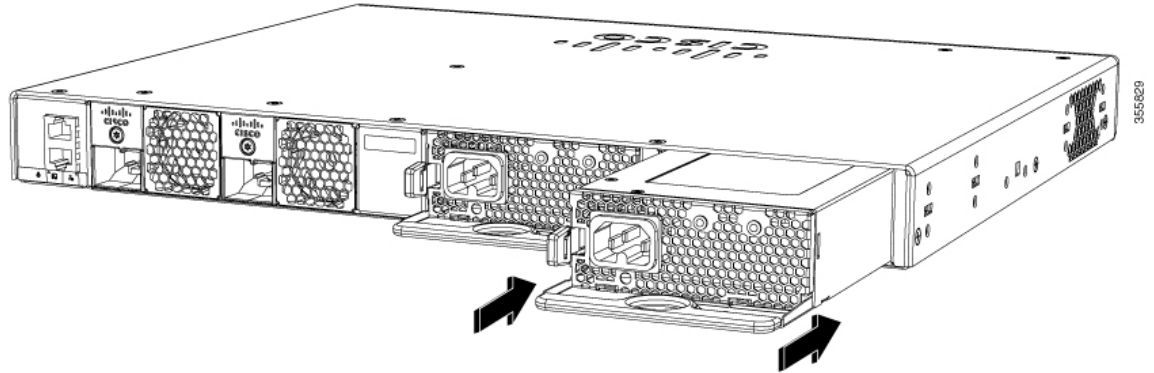

Step 6 (Optional) Install the power cord retainer as follows:

Figure 34: AC-Power Supply with Power Cord Retainer

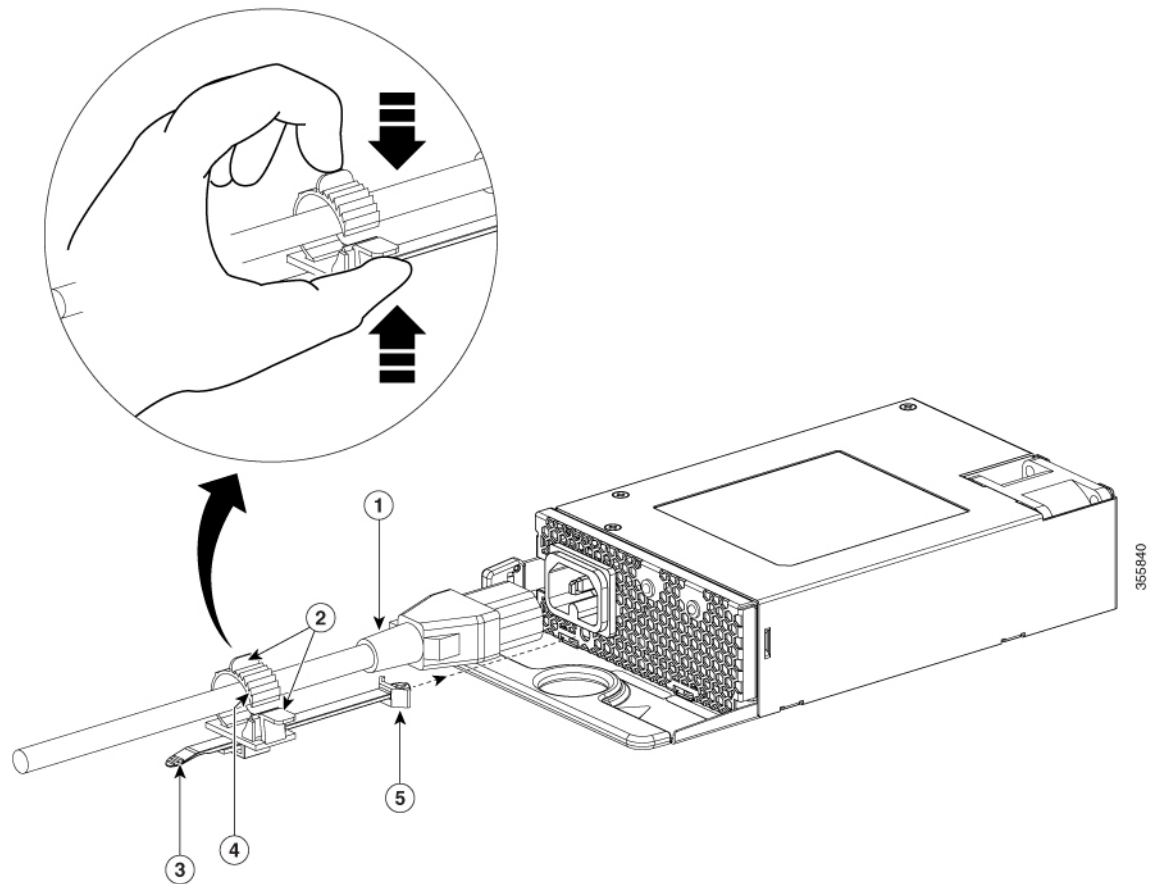

1	Power cord	4	Retainer clamp
2	Tabs on the retainer clamp	5	The strap end that is fixed to the power supply module
3	Power cord retainer strip	-	-

- Fix the strap in the power cord retainer to the power supply module, to hold the clamp in place.
- Slide the retainer clamp around the AC power cord and position the retainer closest to the power supply.

Note Depending on the width of the power cord, adjust the size of the retainer clamp, if required.

- Press the tabs on the retainer clamp towards each other to secure the AC power cord.

Step 7 Connect the power cord to the power supply and to an AC power outlet. Turn on the power at the power source.

Step 8 Confirm that the power supply →] and [← LED are green.



CHAPTER 6

Installing a Fan Module

- [Fan Modules Overview](#) , on page 63
- [Installation Guidelines](#), on page 64
- [Installing a Fan Module](#), on page 65
- [Finding the Fan Module Serial Number](#), on page 65

Fan Modules Overview

Cisco Catalyst 9200 (C9200) Series switches support two field-replaceable fan modules providing N+1 redundancy support. The switch should be able to operate at ambient temperature if one of the fans fails.

Figure 35: Fan Module

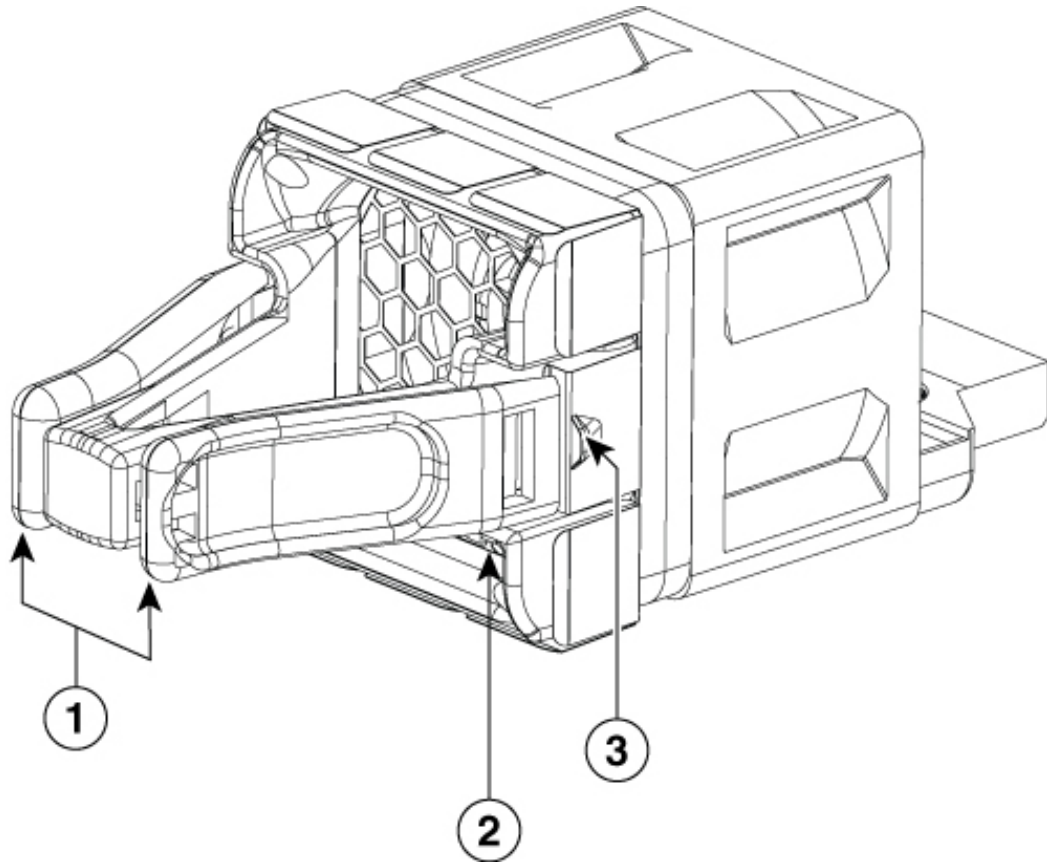

355975

1	Extraction handles	3	Retainer clip
2	Fan LED		

Installation Guidelines

Observe these guidelines when removing or installing a fan module:

- Do not force the fan module into the slot. This can damage the pins on the switch if they are not aligned with the module.
- A fan module that is only partially connected to the switch can disrupt the system operation.
- The switch supports hot swapping of the fan module. You can remove and replace the module without interrupting normal switch operation.



Warning Only trained and qualified personnel should be allowed to install, replace, or service this equipment. Statement 1030

Installing a Fan Module

Procedure

Step 1 Pinch the fan module release handle, and slide the module out.

Caution You should replace the fan module within 5 minutes to avoid overheating the switch.

Step 2 Install the fan module in the fan slot, and firmly push it into the slot, applying pressure to the end of the module, not the extraction handles. When correctly inserted, the fan module is flush with the switch rear panel. When the fan is operating, a green LED is on in the top left corner of the fan.

Figure 36: Installing a Fan Module

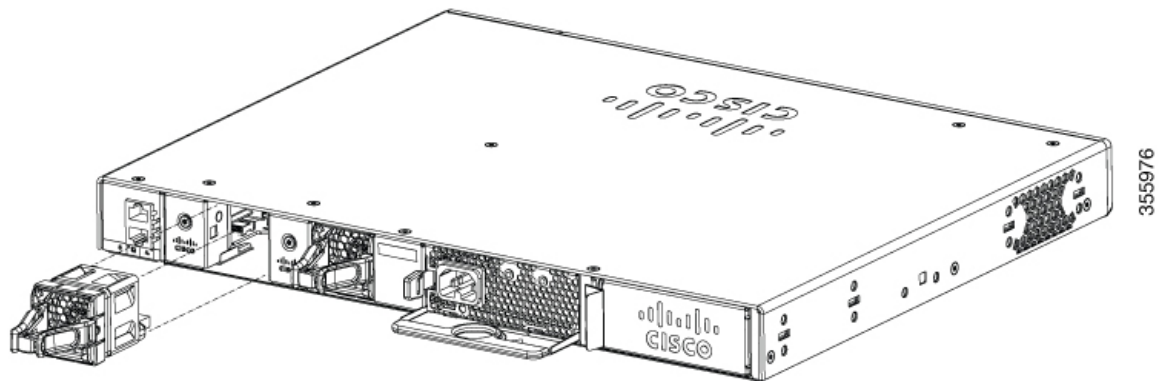

Warning Do not reach into a vacant slot when installing or removing a module. Exposed circuitry is an energy hazard. Statement 206

Finding the Fan Module Serial Number

If you contact Cisco Technical Assistance regarding a fan module, you need to know the fan module serial number. See the following illustration to find the serial number.

Figure 37: Fan Module Serial Number

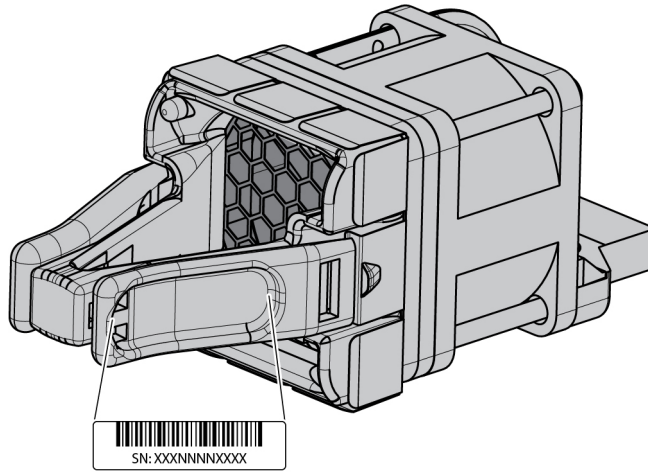



CHAPTER 7

Configuring the Switch

- [Configuring the Switch Using the Web User Interface, on page 67](#)
- [Configuring the Switch Using the CLI, on page 67](#)

Configuring the Switch Using the Web User Interface

For instructions on setting up the switch using the WebUI, refer to the required version of the [software configuration guide](#). In the guide, go to *Configuring the Switch Using the Web User Interface*.

Configuring the Switch Using the CLI

Accessing the CLI Through the Console Port

You can access the CLI on a configured or unconfigured switch by connecting the RJ-45 console port or USB console port of the switch to your PC or workstation and accessing the switch through a terminal emulation program.



Note If you have stacked your switches, connect to the console port of one of the switches in the stack. You can initially configure the entire stack from any member switch.

Connecting the RJ45 Console Port

Procedure

- Step 1** Connect the RJ45 port adapter to the serial port on the terminal server or your PC using the optional RJ45-to-DB9 adapter cable. Connect the other end of the cable to the switch console port.
- Step 2** Start the terminal-emulation program on the PC or the terminal. The program, frequently a PC application such as Putty or TeraTerm, makes communication between the switch and your PC or terminal possible.
- Step 3** Configure the baud rate and character format of the PC or terminal to match the console port default characteristics:

- 9600 baud
- 8 data bits
- 1 stop bit
- No parity
- None (flow control)

Step 4 Power on the switch.

Step 5 The PC or terminal displays the bootloader sequence. Press **Enter** to display the setup prompt.

Connecting the USB Console Port

Before you begin

The Cisco Catalyst 9200 Series Switches will either have the Cisco USB Device or Silicon Labs USB Device (CP2102N). To identify which USB device is in the switch, do the following:

1. Connect a USB cable from the Windows-based PC or Mac-based PC to the USB console port.
2. On the Windows-based PC, open the Device Manager or on the Mac-based PC, open the System Report and view the following:

Type of USB Device	Device Name
Cisco USB device	Cisco USB Console or USB Serial Device
Silicon Labs USB device	Silicon Labs CP210x USB to UART Bridge or CP2102N USB to UART Bridge

Procedure

Step 1 To install the USB driver to a Windows-based PC or Mac-based PC for the first time, do the following:

Windows-based PC

- For Cisco USB Device, see [Installing the Microsoft Windows USB Device Driver, on page 69](#).
- For Silicon Labs USB Device, you can either download the USB driver from the Silicon Labs [website](#) or see [Installing the Silicon Labs Windows USB Device Driver, on page 70](#).

Mac-based PC

- For Cisco USB Device, no driver installation is required.
- For Silicon Labs USB Device, you can download the USB driver from the Silicon Labs [website](#). Once the installation is completed, a virtual COM port session, "tty.SLAB_USBtoUART", will be started.

Note Do not use the generic USB serial driver available on the Mac-based PC.

Note USB Type A port on the switch provides file system support and is **NOT** a console port. See USB Type A Port section.

- Step 2** Connect a USB cable to the PC USB port. Connect the other end of the cable to the switch (5-pin-connector) USB console port.
- Step 3** Start the terminal-emulation program on the PC or the terminal. The program, frequently a PC application such as Putty or TeraTerm, makes communication between the switch and your PC or terminal possible.
- Step 4** Configure the baud rate and character format of the PC or terminal to match the console port default characteristics:
- 9600 baud
 - 8 data bits
 - 1 stop bit
 - No parity
 - None (flow control)
- Step 5** Power on the switch as described in the switch getting started guide.
- Step 6** The PC or terminal displays the bootloader sequence. Press **Enter** to display the setup prompt. Follow the steps in the Setup program.
-

Installing the Microsoft Windows USB Device Driver

A USB device driver must be installed the first time a Microsoft Windows-based PC is connected to the USB console port on the switch.

Installing the Cisco Microsoft Windows USB Driver

Procedure

- Step 1** Obtain the Cisco USB console driver file from the Cisco.com web site and unzip it.
- Note** You can download the driver file from the Cisco.com site for downloading the switch software.
- Windows 10 includes a USB to RS232 driver. However for added functionality, download the USB Console Software from the Software Download Center for Catalyst 3850 Series Switches at cisco.com.
- Step 2** If using 32-bit Windows, double-click the setup.exe file in the Windows_32 folder. If using 64-bit Windows, double-click the setup(x64).exe file in the Windows_64 folder.
- Step 3** The Cisco Virtual Com InstallShield Wizard begins. Click **Next**.
- Step 4** The Ready to Install the Program window appears. Click **Install**.
- Note** If a User Account Control warning appears, click **Allow - I trust this program** to proceed.
- Step 5** The InstallShield Wizard Completed window appears. Click **Finish**.

- Step 6** Connect the USB cable to the PC and the switch console port. The USB console port LED turns green, and the Found New Hardware Wizard appears. Follow the instructions to complete the driver installation.
-

Installing the Silicon Labs Windows USB Device Driver

Procedure

- Step 1** Connect a USB cable to the PC USB port. Connect the other end of the cable to the switch mini-B (5-pin-connector) USB console port.
- Step 2** Launch the Windows Update page by clicking on the **Update & Security** button on the Windows Settings.
- Step 3** Click **View optional updates**.
- Step 4** Expand **Driver updates** and select **Silicon Laboratories Inc. – Ports 10.x.x.x**.
- Step 5** Click **Download and install** button.

Once the driver installation is complete, disconnect the USB cable from the PC USB port and the switch.

Note Windows assigns different COM ports to Silicon Labs USB device. To view the COM port assignment, see Device Manager.

Uninstalling the Cisco Microsoft Windows USB Driver

Uninstalling the Cisco Microsoft Windows USB Driver

Before you begin

Disconnect the switch console terminal before uninstalling the driver.

Procedure

- Step 1** Run setup.exe for Windows 32-bit or setup(x64).exe for Windows-64bit. Click **Next**.
- Step 2** The InstallShield Wizard for Cisco Virtual Com appears. Click **Next**.
- Step 3** When the Program Maintenance window appears, select the Remove radio button. Click **Next**.
- Step 4** When the Remove the Program window appears, click **Remove**.
- Note** If a User Account Control warning appears, click **Allow - I trust this program to proceed**.
- Step 5** When the InstallShield Wizard Completed window appears, click **Finish**.
-



APPENDIX **A**

Technical Specifications

- [Environmental and Physical Specifications, on page 71](#)
- [Specifications for the Power Supplies and Fans, on page 75](#)

Environmental and Physical Specifications

This table describes the environmental specifications.

Table 13: Environmental Specifications for the Switch

Environmental Ranges	
Operating temperature 2	23 to 113°F (–5 to 45°C)
Storage temperature	–40 to 158°F (–40 to 70°C)
Relative humidity	5 to 90% (noncondensing)
Operating altitude	Up to 10,000 ft (3000 m)
Storage altitude	Up to 15,000 ft (4500 m)

² Minimum ambient temperature for cold start is 32°F (0°C)

This table describes the environmental specifications.

Table 14: Environmental Specifications for the Power Supplies

Environmental Ranges	
Operating temperature	23°F to 113°F (–5°C to 45°C) up to 5000 feet (1500m) 23°F to 104°F (–5°C to 40°C) up to 10,000 feet (3000m)
Storage temperature	–40 to 158°F (–40 to 70°C)
Relative humidity	5% to 90% (noncondensing)
Altitude	10,000 ft (3,000 m) up to 45°C

This table describes the physical specifications.

Table 15: Physical Specifications for the Switch

Dimensions (H x W x D)	
Chassis Dimensions	Chassis Dimensions with the FAN FRUs and the power supplies installed
1.73 x 17.5 x 13.8 in. (4.4 x 44.4 x 35 cm) C9200-24P	1.73 x 17.5 x 15.4 in. (4.4 x 44.4 x 39.1 cm) C9200-24P
1.73 x 17.5 x 13.8 in. (4.4 x 44.4 x 35 cm) C9200-24PB	1.73 x 17.5 x 15.4 in. (4.4 x 44.4 x 39.1 cm) C9200-24PB
1.73 x 17.5 x 13.8 in. (4.4 x 44.4 x 35 cm) C9200-48P	1.73 x 17.5 x 15.4 in. (4.4 x 44.4 x 39.1 cm) C9200-48P
1.73 x 17.5 x 13.8 in. (4.4 x 44.4 x 35 cm) C9200-48PB	1.73 x 17.5 x 15.4 in. (4.4 x 44.4 x 39.1 cm) C9200-48PB
1.73 x 17.5 x 13.8 in. (4.4 x 44.4 x 35 cm) C9200-48PL	1.73 x 17.5 x 15.4 in. (4.4 x 44.4 x 39.1 cm) C9200-48PL
1.73 x 17.5 x 13.8 in. (4.4 x 44.4 x 35 cm) C9200-48T	1.73 x 17.5 x 15.4 in. (4.4 x 44.4 x 39.1 cm) C9200-48T
1.73 x 17.5 x 13.8 in. (4.4 x 44.4 x 35 cm) C9200-24PXG	1.73 x 17.5 x 15.4 in. (4.4 x 44.4 x 39.1 cm) C9200-24PXG
1.73 x 17.5 x 13.8 in. (4.4 x 44.4 x 35 cm) C9200-48PXG	1.73 x 17.5 x 15.4 in. (4.4 x 44.4 x 39.1 cm) C9200-48PXG
1.73 x 17.5 x 11.3 in. (4.4 x 44.5 x 28.8 cm) C9200L-24P-4G	1.73 x 17.5 x 12.9 in. (4.4 x 44.5 x 32.9 cm) C9200L-24P-4G
1.73 x 17.5 x 11.3 in. (4.4 x 44.5 x 28.8 cm) C9200L-24P-4X	1.73 x 17.5 x 12.9 in. (4.4 x 44.5 x 32.9 cm) C9200L-24P-4X
1.73 x 17.5 x 11.3 in. (4.4 x 44.5 x 28.8 cm) C9200L-24T-4G	1.73 x 17.5 x 12.9 in. (4.4 x 44.5 x 32.9 cm) C9200L-24T-4G
1.73 x 17.5 x 11.3 in. (4.4 x 44.5 x 28.8 cm) C9200L-24T-4X	1.73 x 17.5 x 12.9 in. (4.4 x 44.5 x 32.9 cm) C9200L-24T-4X
1.73 x 17.5 x 11.3 in. (4.4 x 44.5 x 28.8 cm) C9200L-48P-4G	1.73 x 17.5 x 12.9 in. (4.4 x 44.5 x 32.9 cm) C9200L-48P-4G
1.73 x 17.5 x 11.3 in. (4.4 x 44.5 x 28.8 cm) C9200L-48P-4X	1.73 x 17.5 x 12.9 in. (4.4 x 44.5 x 32.9 cm) C9200L-48P-4X
1.73 x 17.5 x 11.3 in. (4.4 x 44.5 x 28.8 cm) C9200L-48PL-4G	1.73 x 17.5 x 12.9 in. (4.4 x 44.5 x 32.9 cm) C9200L-48PL-4G

1.73 x 17.5 x 11.3 in. (4.4 x 44.5 x 28.8 cm) C9200L-48PL-4X	1.73 x 17.5 x 12.9 in. (4.4 x 44.5 x 32.9 cm) C9200L-48PL-4X
1.73 x 17.5 x 11.3 in. (4.4 x 44.5 x 28.8 cm) C9200L-48T-4G	1.73 x 17.5 x 12.9 in. (4.4 x 44.5 x 32.9 cm) C9200L-48T-4G
1.73 x 17.5 x 11.3 in. (4.4 x 44.5 x 28.8 cm) C9200L-48T-4X	1.73 x 17.5 x 12.9 in. (4.4 x 44.5 x 32.9 cm) C9200L-48T-4X
1.73 x 17.5 x 13.8 in. (4.4 x 44.5 x 35 cm) C9200L-24PXG-4X	1.73 x 17.5 x 15.4 in. (4.4 x 44.5 x 39.1 cm) C9200L-24PXG-4X
1.73 x 17.5 x 13.8 in. (4.4 x 44.5 x 35 cm) C9200L-24PXG-2Y	1.73 x 17.5 x 15.4 in. (4.4 x 44.5 x 39.1 cm) C9200L-24PXG-2Y
1.73 x 17.5 x 13.8 in. (4.4 x 44.5 x 35 cm) C9200L-48PXG-4X	1.73 x 17.5 x 15.4 in. (4.4 x 44.5 x 39.1 cm) C9200L-48PXG-4X
1.73 x 17.5 x 13.8 in. (4.4 x 44.5 x 35 cm) C9200L-48PXG-2Y	1.73 x 17.5 x 15.4 in. (4.4 x 44.5 x 39.1 cm) C9200L-48PXG-2Y

Weight measurement is calculated with one power supply installed.

Table 16: Weight Measurements

Switch Model	Weight
C9200-24T	11 lb (5 kg)
C9200-24P	11 lb (5 kg)
C9200-24PB	11 lb (5 kg)
C9200-48T	11.5 lb (5.2 kg)
C9200-48P	11.5 lb (5.2 kg)
C9200-48PB	11.5 lb (5.2 kg)
C9200-48PL	11.5 lb (5.2 kg)
C9200-24PXG	11.4 lb (5.15 kg)
C9200-48PXG	11.9 lb (5.44 kg)
C9200L-24T-4G	9.6 lb (4.35 kg)
C9200L-24P-4G	10.4 lb (4.71 kg)
C9200L-48T-4G	10 lb (4.53 kg)
C9200L-48P-4G	10.6 lb (4.8 kg)
C9200L-48T-4X	10 lb (4.53 kg)
C9200L-48P-4X	10.6 lb (4.8 kg)

Switch Model	Weight
C9200L-24P-4X	10.4 lb (4.71 kg)
C9200L-24T-4X	9.6 lb (4.35 kg)
C9200L-48PL-4G	10.6 lb (4.8 kg)
C9200L-48PL-4X	10.6 lb (4.8 kg)
C9200L-24PXG-4X	12 lb (5.44 kg)
C9200L-24PXG-2Y	12 lb (5.44 kg)
C9200L-48PXG-4X	12.6 lb (5.71 kg)
C9200L-48PXG-2Y	12.6 lb (5.71 kg)

This table describes the physical specifications.

Table 17: Physical Specifications for the Power Supplies

Weight	
PWR-C5-125WAC	1.5 lb (0.68 kg)
PWR-C5-600WAC	1.7 lb (0.77 kg)
PWR-C5-1KWAC	2 lb (0.9 kg)
PWR-C6-125WAC	1.5 lb (0.68 kg)
PWR-C6-600WAC	1.7 lb (0.77 kg)
PWR-C6-1KWAC	2 lb (0.9 kg)
Dimensions (H x D x W)	
The dimensions shown include the extraction handle and the keying feature.	
PWR-C5-125WAC	1.58 x 4.0 x 7.6 in. (40.1 X 101.6 X 193 mm)
PWR-C5-600WAC	
PWR-C5-1KWAC	
PWR-C6-125WAC	
PWR-C6-600WAC	
PWR-C6-1KWAC	

Specifications for the Power Supplies and Fans

Table 18: Power Specifications for the AC Power Supplies

Power Requirements	
Maximum output power	<ul style="list-style-type: none"> • PWR-C5-125WAC and PWR-C6-125WAC: 125 W • PWR-C5-600WAC and PWR-C6-600WAC: 600 W • PWR-C5-1KWAC and PWR-C6-1KWAC: 1000 W
Input voltage and Frequency	100 to 240 VAC(autoranging) 50-60 Hz
Input current	<ul style="list-style-type: none"> • PWR-C5-125WAC and PWR-C6-125WAC: 1.6-0.7A • PWR-C5-600WAC and PWR-C6-600WAC: 7-2.8A • PWR-C5-1KWAC and PWR-C6-1KWAC: 12-6A
Output ratings	<ul style="list-style-type: none"> • PWR-C5-125WAC and PWR-C6-125WAC: 12V @ 10.5A • PWR-C5-600WAC and PWR-C6-600WAC: 54V @ 11.1A • PWR-C5-1KWAC and PWR-C6-1KWAC: 54V @ 16.5A
Total output BTU	<ul style="list-style-type: none"> • PWR-C5-125WAC and PWR-C6-125WAC: 426.5 BTUs per hour, 125W • PWR-C5-600WAC and PWR-C6-600WAC: 2047.3 BTUs per hour, 600W • PWR-C5-1KWAC and PWR-C6-1KWAC: 3412 BTUs per hour, 1000W

Table 19: Fan Module Environmental and Physical Specifications

Environmental Ranges	
Operating temperature	23 to 176°F (−5 to 80°C)
Storage temperature	−40 to 185°F (−40 to 85°C) up to 15,000 ft (4500 m)
Relative humidity	5 to 95% (noncondensing)
Altitude	Up to 13,000 ft (4000 m)
Physical Specification	
Dimensions (H x D x W)	1.62 x 1.73 x 4.24 in. (4.11 x 4.39 x 10.76 cm)
Weight (for three fans)	0.48 lb (0.21 kg)

Operating Specification	
Airflow	20 cfm



APPENDIX **B**

Switch LEDs

- LEDs, on page 77
- Console LED, on page 78
- System LED, on page 78
- ACTIVE LED, on page 78
- STACK LED, on page 79
- PoE LED, on page 80
- Port LEDs and Modes, on page 80
- Beacon LED, on page 83
- RJ-45 Console Port LED, on page 83
- Fan LED, on page 83
- Uplink Port LEDs, on page 83

LEDs

Switch Front Panel LEDs

You can use the switch LEDs to monitor switch activity and its performance.

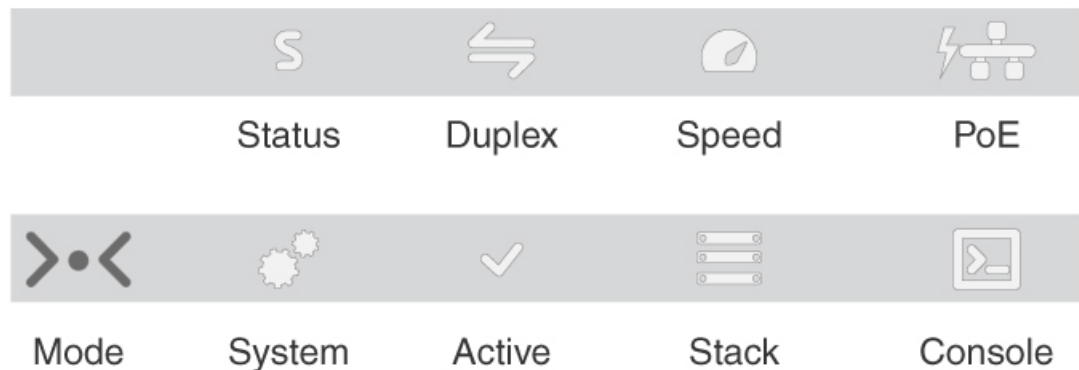

355846

Console LED

The console LED indicates whether the USB console port or the bluetooth console is enabled.

Table 20: Console LED

LED	Color	Description
Console	Solid green	USB Mini-Type B console port is active.
	Off	USB cable not connected

System LED

Table 21: System LED

Color	System Status
Off	System is not powered on.
Green	System is operating normally.
Blinking green	System is loading the software.
Amber	System is receiving power but is not functioning properly.
Blinking amber	There is a fault with one of the following: <ul style="list-style-type: none"> • Network module (non traffic-related) • Power supply • Fan module

ACTIVE LED

Table 22: ACTIVE LED

Color	Description
Off	Switch is not the active switch.
Green	Switch is the stack's active switch or a standalone switch.
Fast blinking green	Switch is in stack standby mode.
Amber	An error occurred when the switch was selecting the stack's active switch, or another type of stack error occurred.

STACK LED

The STACK LED shows the sequence of member switches in a stack. Up to eight switches can be members of a stack. The first eight port LEDs show the member number of a switch in a stack.

Figure 38: STACK LED

This figure shows the LEDs on for each switch. When you press the Mode button to select the STACK LED, the corresponding port LEDs will blink green for each switch. For example, for switch 1, port 1 will blink green and the rest of the LEDs will be off. On switch 2, port 2 will blink green and the rest of the LEDs will be off. The same behavior will be seen with the remaining switches in the stack.

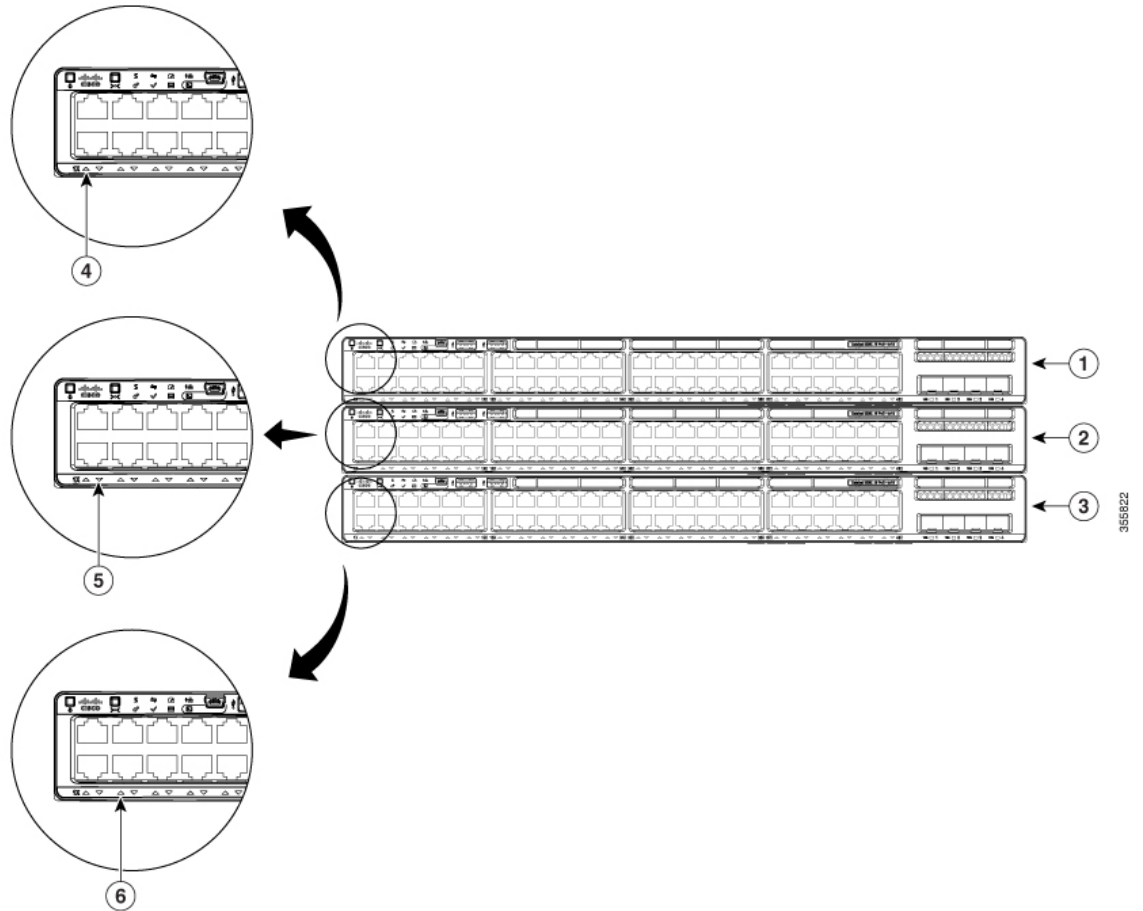

1 Stack member 1	4 LED blinks green to show that this is switch 1 in the stack.
2 Stack member 2	5 LED blinks green to show that this is switch 2 in the stack.
3 Stack member 3	6 LED blinks green to show that this is switch 3 in the stack.

PoE LED

The PoE LED indicates the status of the PoE mode: either PoE or PoE+.

Table 23: PoE LED

Color	Description
Off	PoE mode is not selected. None of the 10/100/1000 ports have been denied power or are in a fault condition.
Green	PoE mode is selected, and the port LEDs show the PoE mode status.

Port LEDs and Modes

Each Ethernet port, 1-Gigabit Ethernet module slot, and 10-Gigabit Ethernet module slot has a port LED. These port LEDs, as a group or individually, display information about the switch and about the individual ports. The port mode determines the type of information shown by the port LEDs.

To select or change a mode, press the Mode button until the desired mode is highlighted. When you change port modes, the meanings of the port LED colors also change.

When you press the Mode button on any switch in the switch stack, all the stack switches change to show the same selected mode. For example, if you press the Mode button on the active switch to show the SPEED LED, all the other switches in the stack also show the SPEED LED.

Table 24: Port Mode LEDs

Mode LED	Port Mode	Description
STAT	Port status	The port status. This is the default mode.
SPEED	Port speed	The port operating speed: 10, 100, or 1000 Mb/s.
DUPLX	Port duplex mode	The port duplex mode: full duplex or half duplex.
ACTV	Active	The active switch status.
STACK	Stack member status StackWise port status	Stack member status. The StackWise port status. See STACK LED , on page 79.
PoE ³	The PoE+ port status.	The PoE+ port status.

³ Only switches with PoE+ ports.

Table 25: Meaning of Switch LED Colors in Different Modes

Port Mode	Port LED Color	Meaning
STAT (port status)	Off	No link, or port was administratively shut down.
	Green	Link present, no activity.
	Blinking green	Activity. Port is sending or receiving data.
	Alternating green-amber	Link fault. Error frames can affect connectivity, and errors such as excessive collisions, CRC errors, and alignment and jabber errors are monitored for a link-fault indication.
	Amber	Port is blocked by Spanning Tree Protocol (STP) and is not forwarding data. After a port is reconfigured, the port LED can be amber for up to 30 seconds as STP checks the switch for possible loops.
SPEED	Off	Port is operating at 10 Mb/s.
	Green	Port is operating at 100 Mb/s.
	Blinking green (on for 100 ms, off for 1900 ms)	Port is operating at 1000 Mb/s.
	Blinking green (on for 200 ms, off for 1800 ms)	Port is operating at 2500 Mb/s.
	Blinking green (on for 400 ms, off for 1600 ms)	Port is operating at 5000 Mb/s.
	Blinking green (on for 800 ms, off for 1200 ms)	Port is operating at 10 G.
	Blinking green (on for 1200 ms, off for 800 ms)	Port is operating at 25 G.
	Blinking green (two intervals) (First Interval: on for 200 ms, off for 200 ms) (Second Interval: on for 200 ms, off for 1400 ms)	Port is operating at 40 G.
DUPLX (duplex)	Off	Port is operating in half duplex.
	Green	Port is operating in full duplex.

Port Mode	Port LED Color	Meaning
ACTV (data active switch)	Off	The switch is not the active switch. Note For a standalone switch, this LED is off.
	Green	The switch is the active switch.
	Amber	Error during active switch election.
	Blinking green	Switch is a standby member of a data stack and assumes active responsibilities if the current active switch fails.
STACK (stack member)	Off	No stack member corresponding to that member number.
	Blinking green	Stack member number.
	Green	Member numbers of other stack member switches.
PoE ⁴	Off	PoE+ is off. If the powered device is receiving power from an AC power source, the port LED is off even if the device is connected to the switch port.
	Green	PoE+ is on. The port LED is green when the switch port is providing power.
	Alternating green-amber	PoE+ is denied because providing power to the powered device will exceed the switch power capacity.
	Blinking amber	PoE+ is off due to a fault or because it has exceeded a limit set in the switch software. Caution PoE+ faults occur when noncompliant cabling or powered devices are connected to a PoE+ port. Use only standard-compliant cabling to connect Cisco prestandard IP Phones and wireless access points or IEEE 802.3af-compliant devices to PoE+ ports. You must remove from the network any cable or device that causes a PoE+ fault.
	Amber	PoE+ for the port has been disabled. Note PoE+ is enabled by default

⁴ Only switches with PoE or PoE+ ports.

Beacon LED

The beacon LED on the front panel of the switch can be turned on by the administrator to indicate that the switch needs attention. It helps the administrator identify the switch. The beacon can be turned on by either pressing the button on the switch front panel, or by using the CLI.

Color/State	Description
Solid blue	The operator has indicated that the system needs attention.

RJ-45 Console Port LED

Table 26: RJ-45 Console Port LED

Color	RJ-45 Console Port Status
Off	RJ-45 console is disabled. USB console is active.
Green	RJ-45 console is enabled. USB console is disabled.

Fan LED

Table 27: Fan LED Indicator

Color/State	Description
Off	The fan is not receiving power; the fans have stopped.
Green	All fans are operating normally.
Amber	One or more fans have encountered tachometer faults.
Red	One or more fans' tachometer faults have exceeded the maximum limit.

Uplink Port LEDs

The uplink ports have various status LEDs. Each port LED is labeled according to its module status.

- For SFP ports, a G labeling nomenclature is used, where G = 1 Gigabit. The G label appears to the left of the uplink port LED.
- For SFP+ ports, a 10G labeling nomenclature is used, where 10G = 10 Gigabit. The 10G label appears to the left of the uplink port LED. SFP+ module ports support both SFP+ and SFP modules

- For SFP28 ports, a 25G labeling nomenclature is used, where 25G = 25 Gigabit. The The G label appears to the left of the uplink port LED.
- For QSFP+ ports, a 40G labeling nomenclature is used, where 40G = 40 Gigabit. The The G label appears to the left of the uplink port LED.

Figure 39: SFP+ Port LEDs

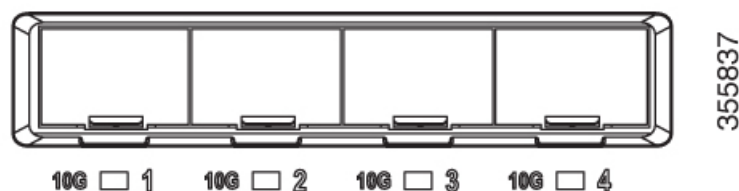

Color	Network Module Link Status
Off	Link is off.
Green	Link is on; no activity.
Blinking green	Activity on a link; no faults. Note The LED will blink green even when there is very little control traffic.
Blinking amber	Link is off due to a fault or because it has exceeded a limit set in the switch software. Caution Link faults occur when non-compliant cabling is connected to an SFP/SFP+ port. Use only standard-compliant cabling to connect to Cisco SFP/SFP+ ports. You must remove from the network any cable or device that causes a link fault.
Amber	Link for the SFP/SFP+/SFP28/QSFP+ has been disabled.

THE SPECIFICATIONS AND INFORMATION REGARDING THE PRODUCTS IN THIS MANUAL ARE SUBJECT TO CHANGE WITHOUT NOTICE. ALL STATEMENTS, INFORMATION, AND RECOMMENDATIONS IN THIS MANUAL ARE BELIEVED TO BE ACCURATE BUT ARE PRESENTED WITHOUT WARRANTY OF ANY KIND, EXPRESS OR IMPLIED. USERS MUST TAKE FULL RESPONSIBILITY FOR THEIR APPLICATION OF ANY PRODUCTS.

THE SOFTWARE LICENSE AND LIMITED WARRANTY FOR THE ACCOMPANYING PRODUCT ARE SET FORTH IN THE INFORMATION PACKET THAT SHIPPED WITH THE PRODUCT AND ARE INCORPORATED HEREIN BY THIS REFERENCE. IF YOU ARE UNABLE TO LOCATE THE SOFTWARE LICENSE OR LIMITED WARRANTY, CONTACT YOUR CISCO REPRESENTATIVE FOR A COPY.

The following information is for FCC compliance of Class A devices: This equipment has been tested and found to comply with the limits for a Class A digital device, pursuant to part 15 of the FCC rules. These limits are designed to provide reasonable protection against harmful interference when the equipment is operated in a commercial environment. This equipment generates, uses, and can radiate radio-frequency energy and, if not installed and used in accordance with the instruction manual, may cause harmful interference to radio communications. Operation of this equipment in a residential area is likely to cause harmful interference, in which case users will be required to correct the interference at their own expense.

The following information is for FCC compliance of Class B devices: This equipment has been tested and found to comply with the limits for a Class B digital device, pursuant to part 15 of the FCC rules. These limits are designed to provide reasonable protection against harmful interference in a residential installation. This equipment generates, uses and can radiate radio frequency energy and, if not installed and used in accordance with the instructions, may cause harmful interference to radio communications. However, there is no guarantee that interference will not occur in a particular installation. If the equipment causes interference to radio or television reception, which can be determined by turning the equipment off and on, users are encouraged to try to correct the interference by using one or more of the following measures:

- Reorient or relocate the receiving antenna.
- Increase the separation between the equipment and receiver.
- Connect the equipment into an outlet on a circuit different from that to which the receiver is connected.
- Consult the dealer or an experienced radio/TV technician for help.

Modifications to this product not authorized by Cisco could void the FCC approval and negate your authority to operate the product.

The Cisco implementation of TCP header compression is an adaptation of a program developed by the University of California, Berkeley (UCB) as part of UCB's public domain version of the UNIX operating system. All rights reserved. Copyright © 1981, Regents of the University of California.

NOTWITHSTANDING ANY OTHER WARRANTY HEREIN, ALL DOCUMENT FILES AND SOFTWARE OF THESE SUPPLIERS ARE PROVIDED "AS IS" WITH ALL FAULTS. CISCO AND THE ABOVE-NAMED SUPPLIERS DISCLAIM ALL WARRANTIES, EXPRESSED OR IMPLIED, INCLUDING, WITHOUT LIMITATION, THOSE OF MERCHANTABILITY, FITNESS FOR A PARTICULAR PURPOSE AND NONINFRINGEMENT OR ARISING FROM A COURSE OF DEALING, USAGE, OR TRADE PRACTICE.

IN NO EVENT SHALL CISCO OR ITS SUPPLIERS BE LIABLE FOR ANY INDIRECT, SPECIAL, CONSEQUENTIAL, OR INCIDENTAL DAMAGES, INCLUDING, WITHOUT LIMITATION, LOST PROFITS OR LOSS OR DAMAGE TO DATA ARISING OUT OF THE USE OR INABILITY TO USE THIS MANUAL, EVEN IF CISCO OR ITS SUPPLIERS HAVE BEEN ADVISED OF THE POSSIBILITY OF SUCH DAMAGES.

Any Internet Protocol (IP) addresses and phone numbers used in this document are not intended to be actual addresses and phone numbers. Any examples, command display output, network topology diagrams, and other figures included in the document are shown for illustrative purposes only. Any use of actual IP addresses or phone numbers in illustrative content is unintentional and coincidental.

All printed copies and duplicate soft copies of this document are considered uncontrolled. See the current online version for the latest version.

Cisco has more than 200 offices worldwide. Addresses and phone numbers are listed on the Cisco website at www.cisco.com/go/offices.

The documentation set for this product strives to use bias-free language. For purposes of this documentation set, bias-free is defined as language that does not imply discrimination based on age, disability, gender, racial identity, ethnic identity, sexual orientation, socioeconomic status, and intersectionality. Exceptions may be present in the documentation due to language that is hardcoded in the user interfaces of the product software, language used based on standards documentation, or language that is used by a referenced third-party product.

Cisco and the Cisco logo are trademarks or registered trademarks of Cisco and/or its affiliates in the U.S. and other countries. To view a list of Cisco trademarks, go to this URL: <https://www.cisco.com/c/en/us/about/legal/trademarks.html>. Third-party trademarks mentioned are the property of their respective owners. The use of the word partner does not imply a partnership relationship between Cisco and any other company. (1721R)

© 2018–2022 Cisco Systems, Inc. All rights reserved.

